

FMZ CONNECTOR



Connectors for FFC and FPC



The FMZ series, a Zero Insertion Force (ZIF) connector series, was developed to increase wear resistance and extend the connector's mating life. It is a very compact connector with a thickness of only 4.2mm (.165") and a pitch of only 1.0mm (.039") and is thus useful for high density packaging. The contact has a reliable double-leaf construction which provides stable connection.

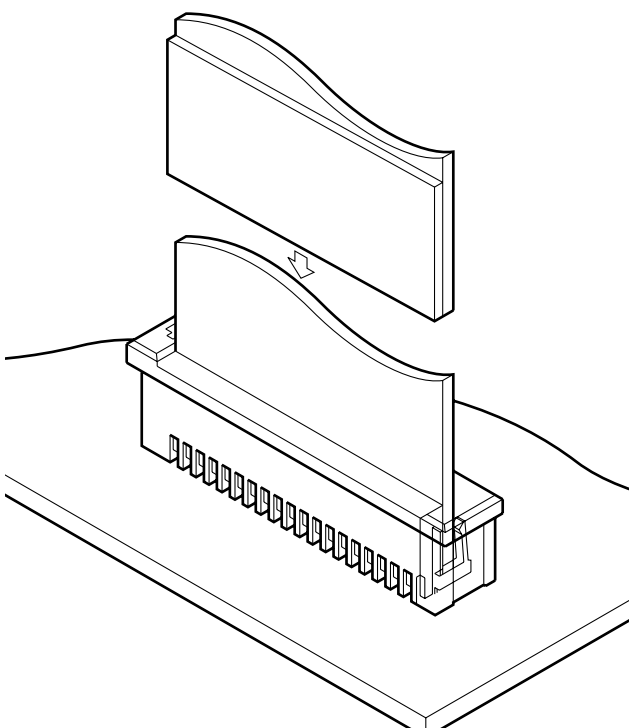

Features

• Zero insertion force mechanism

A ZIF mechanism increases wear resistance and extends the connector's mating life. By moving the slide into its locking position after an FFC or FPC is inserted into the connector with a low insertion force, the FFC or FPC leads are securely locked in place.

• Temporary retention feature

After the FFC or FPC is inserted, but before the locking slide is actuated, a retention feature prevents the FFC or FPC leads from moving or coming out. This allows one handed operation and higher work efficiency.

• Compact

This connector is very small with a mounting height of only 6.5mm (.256") and a thickness of 4.2mm (.165") when locked.

• Double-leaf contact

The slide mechanism and FFC or FPC are held and locked between the contact beams. This eliminates stress to the housing, provides high contact pressure and reliable connection.

Specifications

- Current rating: 0.5A AC, DC
 - Voltage rating: 50V AC, DC
 - Temperature range: -25°C to +85°C
(including temperature rise in applying electrical current)
 - Contact resistance: Initial value/20mΩ max.
After environmental testing/30mΩ max.
 - Insulation resistance: 800MΩ min.
 - Withstanding voltage: 500V AC/minute
 - Applicable FFC and FPC: Lead pitch /1.0mm(.039")
Note: Lead width /0.7mm(.028")
Mating part thickness /
8 to 10, 12 to 16, 20 circuits:
0.30 ± 0.05mm(.012± .002)
22, 26, 28, 30 circuits:
0.30^{+0.05}₀ mm(.012" ^{+0.002})
 - Applicable PC board thickness: 0.8 to 1.6mm(.031" to .063")
Note: These are reference values. FFC/FPC to be actually used should be checked for applicability.
- * Contact JST for details.

Standards

Recognized file No. E60389

Certified file No. LR20812

FMZ CONNECTOR

Connector

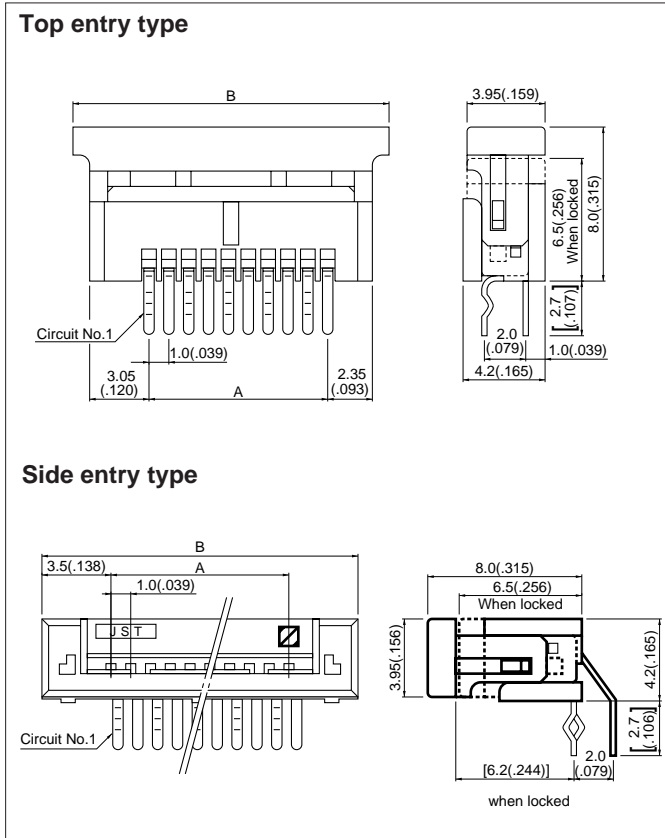

Cir- cuits	Model No.		Dimensions mm(in.)		Q'ty / box	
	Top entry type	Side entry type	A	B	Top entry type	Side entry type
6	06FMZ-BT	—	5.0 (.197)	12.0 (.472)	1,440	—
8	08FMZ-BT	08FMZ-ST	7.0 (.276)	14.0 (.551)	1,440	800
9	09FMZ-BT	09FMZ-ST	8.0 (.315)	15.0 (.591)	960	600
10	10FMZ-BT	10FMZ-ST	9.0 (.354)	16.0 (.630)	960	600
12	12FMZ-BT	12FMZ-ST	11.0 (.433)	18.0 (.709)	960	600
13	13FMZ-BT	13FMZ-ST	12.0 (.472)	19.0 (.748)	960	600
14	14FMZ-BT	14FMZ-ST	13.0 (.512)	20.0 (.787)	960	600
15	15FMZ-BT	15FMZ-ST	14.0 (.551)	21.0 (.827)	780	600
16	16FMZ-BT	16FMZ-ST	15.0 (.591)	22.0 (.866)	800	400
20	20FMZ-BT	20FMZ-ST	19.0 (.748)	26.0 (1.024)	720	400
22	22FMZ-BT	22FMZ-ST	21.0 (.827)	28.0 (1.102)	720	400
26	26FMZ-BT	26FMZ-ST	25.0 (.984)	32.0 (1.260)	480	300
28	28FMZ-BT	28FMZ-ST	27.0 (1.063)	34.0 (1.339)	480	300
30	30FMZ-BT	30FMZ-ST	29.0 (1.142)	36.0 (1.417)	480	400

Material and Finish

Contact: Phosphor bronze, tin-plated
Housing: Glass-filled PBT, UL94V-0, black

Lead section dimensions of FFC and FPC

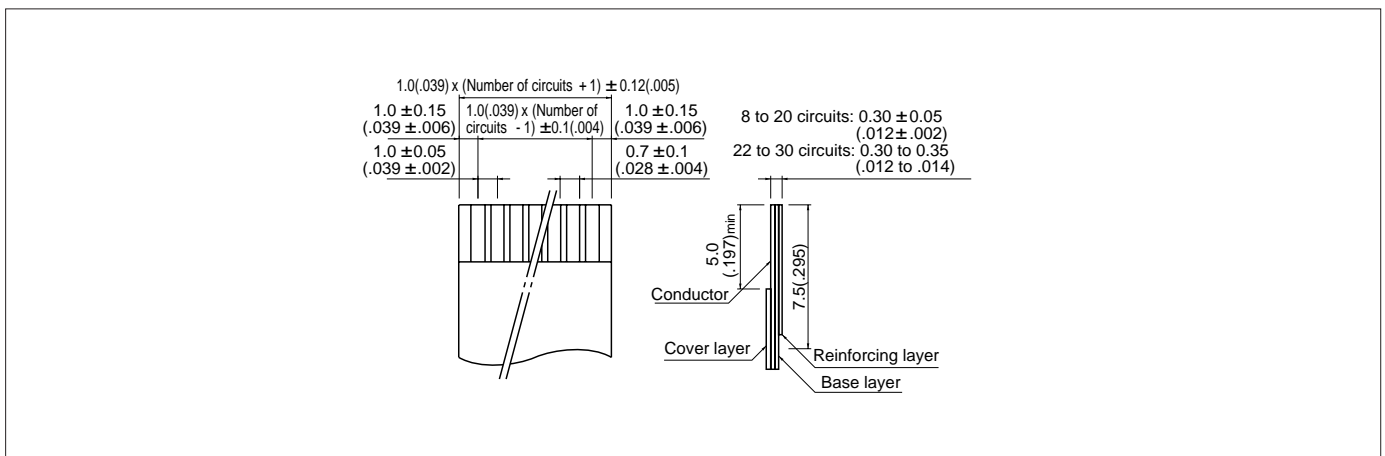

FMZ CONNECTOR

PC board layout (viewed from soldering side) and Assembly layout

Top entry type

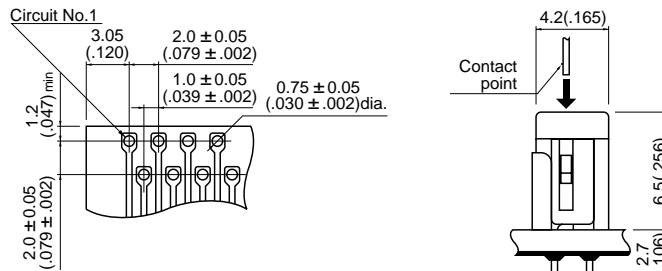

Side entry type

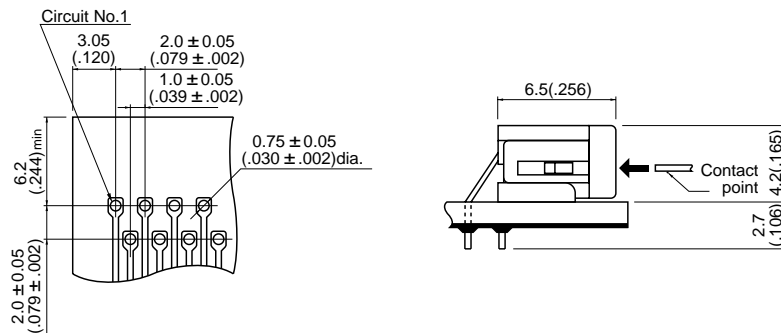

Note:

1. Tolerances are non-cumulative: $\pm 0.05\text{mm} (\pm .002")$ for all centers.
2. Hole dimensions differ according to the kind of PC board and piercing method. The dimensions above should serve as a guideline.
Contact JST for details.