

SPECIFICATION

FOR TFT+TP MODULE

MODEL NO:	TM070DVHG01
CUSTOMER:	
CUSTOMER P/N.	
VERSION	V0.1
CUSTOMER APPROVED	

- Preliminary specification
- Final specification

PREPARED BY	CHECKED BY	VERIFIED BY QA DEPT.	APPROVED BY

TIANMA MICRO-ELECTRONICS CO., LTD

Address: 8F, 64th Building, Jinlong, Majialong Industrial Area, Nanshan District, Shenzhen, China Tel:
+86-755-26094288 Fax: +86-755-86225774 Web: www.tianma.cn www.tianma.com

TFT+TP REVISION RECORD

Version	Page	Revision Items	Name	Date
0.1		First release	Tao chengfeng	2013.05.27

Table of Contents

1. General Specifications	3
2. Input/Output Terminals	6
2.1 TFTCN1 pin assignment	6
2.2 TP pin assignment.....	7
3. Absolute Maximum Ratings.....	8
4. Electrical Characteristics	8
5. Timing Chart	10
6. Optical Characteristics	14
6.1 TFT Optical Characteristics.....	14
6.2 TP Optical Characteristics.....	16
7. Reliability Test	17
8. Mechanical Drawing.....	19
9. Product Inspection Criteria	20
10. Precautions for Use of LCD Modules	25

1 General Specifications

TM070DVHG01 is a color active matrix LCD module incorporating amorphous silicon TFT (Thin Film Transistor). It is composed of a color TFT-LCD panel, driver IC with CABC function, FPC, a back light unit and CTP (Capacitive Touch Panel) with Multi-Touch function. The mounting method is with optical bonding . This product accords with RoHS environmental criterion.

Item	Feature	Spec	Unit	Note
TFT	Size	7.0 inch	inch	--
	Resolution	1024 RGB (H)×600(V)	--	--
	Interface	LVDS 40 Pin	--	--
	Color Depth	16.7 M	--	--
	Technology Type	a-si TFT	--	--
	Pixel Pitch	0.150×0.150	mm	--
	Pixel Configuration	RGB stripe	--	--
	Display Mode	Normally White	--	--
	Surface Treatment(Up Polarizer)	Anti-Glare(3H)	--	--
	Viewing Direction	12 o'clock	--	1
	Gray Scale Inversion Direction	6 o'clock	--	--
	LCM (W x H x D)	165.75(w)×105.39(H)×3.40 (D)	mm	--
TP	Operation Technology	Projected capacitive	--	--
	Control IC	NT11003	--	--
	Input Method	Bare finger	--	--
	Number of simultaneous touches	2 points	--	--
	Surface hardness	--	--	--
	Minimum Touch Area	Φ6	mm	--
	Finger Pitch	13	mm	--
	Product structure	Glass Lens – Glass Sensor	--	2
	Interface	I2C		
Mechanical Characteristics	TFT Active Area	153.6(H)×90.0(V)	mm	--
	TP Active Area	155.24(W) x 87.12(H)	mm	--
	LED Numbers	18 LEDs	--	--
	Weight	--	g	--

Reliability Characteristics	Operation temperature	-20~70	°C	--
	Storage temperature	-30~80	°C	--

Note 1: Viewing direction for best image quality is different from Gray Scale Inversion Direction, there is a 180 degree shift.

Note 2: Requirements on Environmental Protection: RoHS

2. Input/Output Terminals

2.1 TFT CN1 pin assignment

Pin No.	Symbol	I/O	function	Remarks
1	VCOM	P	Common Voltage	
2	VDD	P	Power Voltage for digital circuit	
3	VDD	P	Power Voltage for digital circuit	
4	NC	---	No connection	
5	Reset	I	Global reset pin	Active Low to enter Reset State
6	STBYB	I	Standby mode, Normally pulled high	STBYB="1", Normally operation STBYB="0", Timing controller, source driver will turn off, all output are High-Z
7	GND	P	Ground	
8	RXIN0-	I	- LVDS differential data input	
9	RXIN0+	I	+LVDS differential data input	
10	GND	P	Ground	
11	RXIN1-	I	-LVDS differential data input	
12	RXIN1+	I	+LVDS differential data input	
13	GND	P	Ground	
14	RXIN2-	I	-LVDS differential data input	
15	RXIN2+	I	+LVDS differential data input	
16	GND	P	Ground	
17	RXCLKIN-	I	-LVDS differential clock input	
18	RXCLKIN+	I	+LVDS differential clock input	
19	GND	P	Ground	
20	RXIN3-	I	-LVDS differential data input	
21	RXIN3+	I	+LVDS differential data input	
22	GND	P	Ground	
23	NC	---	No connection	
24	NC	---	No connection	
25	GND	P	Ground	
26	NC	---	No connection	
27	DIMO	O	Backlight CABG controller signal output	Normally Pull High
28	SELB	I	6bit/8bit mode select	Note 2
29	AVDD	P	Power for Analog Circuit	
30	GND	P	Ground	
31	LED-	P	LED Cathode	
32	LED-	P	LED Cathode	
33	L/R	P	Horizontal inversion	L/R=1, from left to right; L/R=0, from right to left
34	U/D	P	Vertical inversion	U/D=0, from up to down; U/D=1, from down to up.
35	VGL	---	Gate OFF Voltage	
36	CABCEN1	---	CABC H/W enable	Note 3

37	CABCEN2	P	CABC H/W enable	Note 3
38	VGH	P	Gate ON Voltage	
39	LED+	P	LED Anode	
40	LED+	P	LED Anode	

Note 1: I/O definition.

I---Input pin, O---Output pin, P--- Power/Ground, N--- No Connection

Note2: If LVDS input data is 6 bits ,SELB must be set to High;
If LVDS input data is 8 bits ,SELB must be set to Low.

Note3: When CABC_EN="00", CABC OFF.

When CABC_EN="01", user interface image.

When CABC_EN="10", still picture.

When CABC_EN="11", moving image.

When CABC off, don't connect DIMO, else connect it to backlight.

Note4:

Scan Control Input		Scanning Direction
UPDN	SHLR	
GND	VDD	Up to Down, Left to Right
VDD	GND	Down to Up, Right to Left
GND	GND	Up to Down, Right to Left
VDD	VDD	Down to Up, Left to Right

2.2 TP pin assignment

Pin No.	Symbol	I/O	Description	Remark
1	SCL	I	I2C clock input	
2	SDA	I/O	I2C data input and output	
3	GND	P	Groud	
4	GND	P	Groud	
5	ATTN	I/O	External interrupt to the host	
6	GND	P	Groud	
7	VPP	I/O	External interrupt from the host	
8	VDD	P	CTP power supply	
9	GND	P	Groud	
10	GND	P	Groud	

3. Absolute Maximum Ratings

Ta = 25°C

Item	Symbol	Min	Max	Unit	Remark
Power Voltage	VDD	-0.3	5.0	V	
	AVDD	6.5	13.5	V	
	VGH	-0.3	20.0	V	
	VGL	-20.0	0.3	V	
Backlight Forward Current	I _{LED}	-	25	mA	For each LED
Operating Temperature	T _{OPR}	-20	70	°C	
Storage Temperature	T _{STG}	-30	80	°C	

Table 3.1 absolute maximum rating

Note1: The parameter is for driver IC (gate driver, source driver) only

Note2: 80°C is the surface temperature of module

Electrical Characteristics

4.1 .1Driving TFT LCD Panel

Item	Symbol	Min	Typ	Max	Unit	Remark
Digital Supply Voltage	VDD	3.0	3.3	3.6	V	
Analog Supply Voltage	AVDD	10.8	11.0	11.2	V	
Gate On Voltage	VGH	15.7	16.0	16.3	V	
Gate Off Voltage	VGL	-7.1	-6.8	-6.5	V	
Common Electrode Driving Signal	VCOM	3.45	3.55	3.65	V	With the VR Knob

Ta = 25°C

Table 4.1 LCD module electrical characteristics

Note1: For different LCM, the value may have a bit of difference.

4.1.2 TFT Driving Backlight

Item	Symbol	Condition	Min	Typ	Max	Unit	Remark
Forward Current	I _F	-	120	-	mA	V	18 LEDs (3 LED Serial, 6 LED Parallel)
Forward Voltage	V _F	-	9.3	-	V	mA	
Operating Life Time	-	15000	-	-	Hrs	mW	

Table 4.2 LED backlight characteristics

Note1: The LED driving condition is defined for each LED module (3 LED Serial, 6 LED Parallel). For each LED: $I_F (1/6) = 20\text{mA}$, $V_F (1/3) = 3.3\text{V}$.

Note2: Under LCM operating, the stable forward current should be inputted. And forward voltage is for reference only.

Note3: I_F is defined for one channel LED. Optical performance should be evaluated at $T_a = 25^\circ\text{C}$ only. If LED is driven by high current, high ambient temperature & humidity condition. The life time of LED will be reduced. Operating life means brightness goes down to 50% initial brightness. Typical operating life time is estimated data.

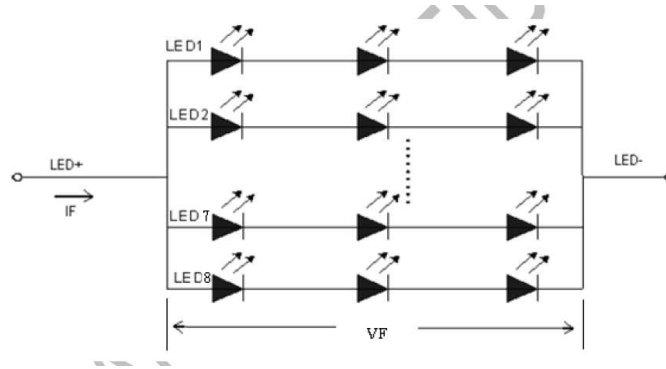

Figure 4.2 LED connection of backlight

4.2 TP DC Characteristics

($T_A = 25^\circ\text{C}$, $V_{DD} = 3.3\text{V}$)

Item	Min	Typ	Max	Unit	Note
power supply voltage	2.7	3.3	3.6	V	DC(noise should be under 100mV)
Power supply current	--	--	10	mA	

4.3.1 TFT Block Diagram

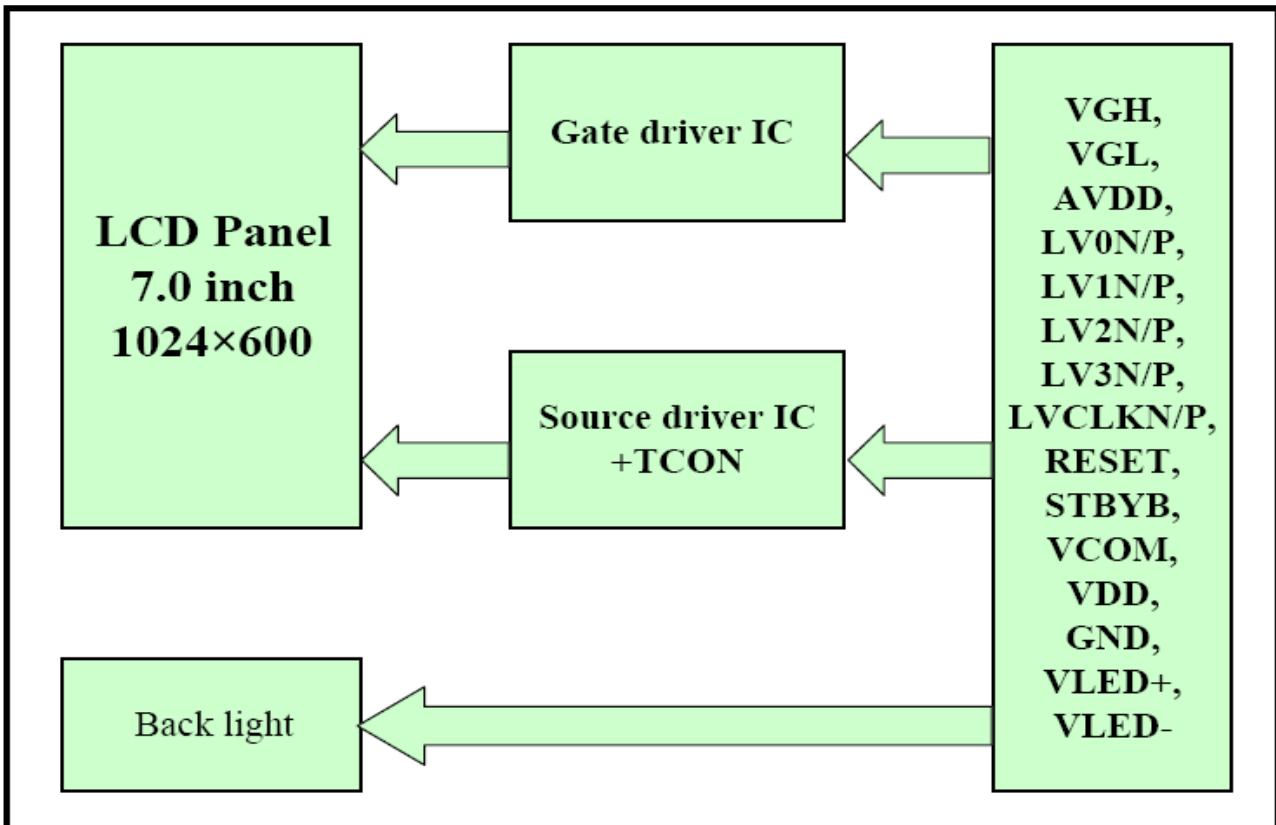

4.3.2 TP Circuit Block Diagram

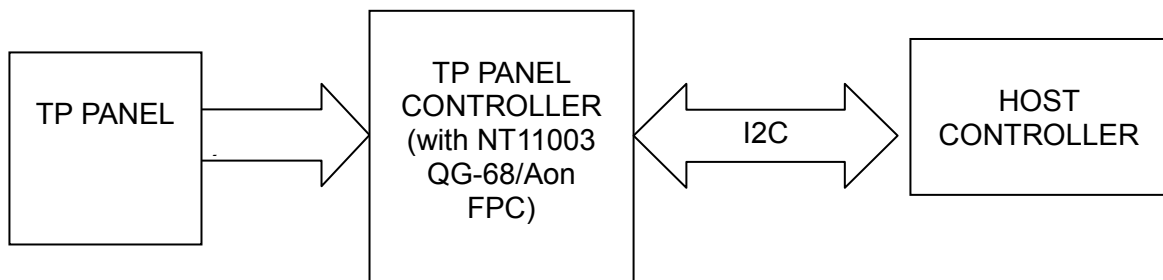

Timing Chart

5.1AC Electrical Characteristics

Parameter	Symbol	Min	Typ	Max	Unit	Conditions
Clock Frequency	R_{xFCLK}	40.8	51.2	71	MHz	
Input data skew margin	T_{RSKM}	500	-	-	ps	
Clock high time	T_{LVCH}	-	$4/(7 * R_{xFCLK})$	-	ns	
Clock low time	T_{LVCL}	-	$3/(7 * R_{xFCLK})$	-	ns	

PLL wake-up time	T_{enPLL}	-	-	150	us	
------------------	-------------	---	---	-----	----	--

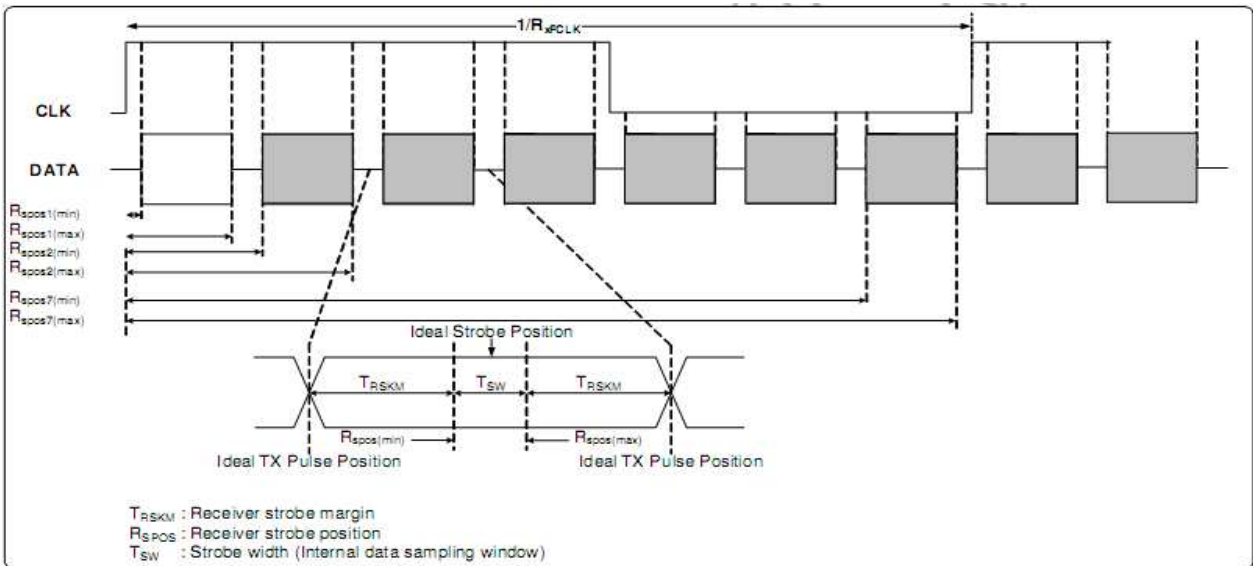
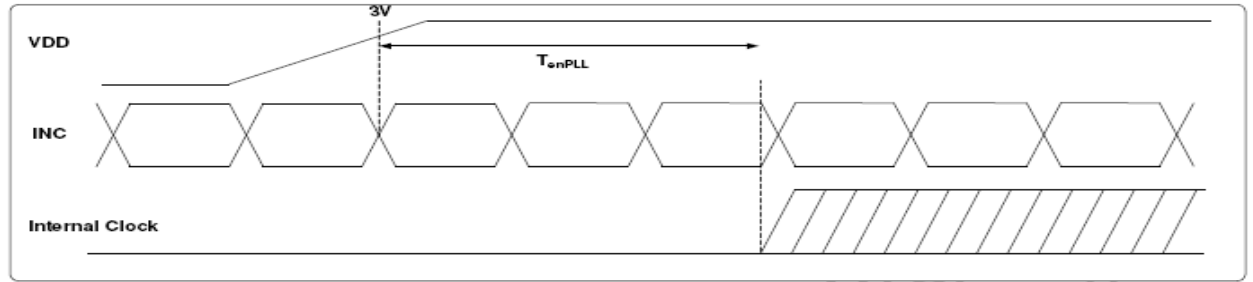
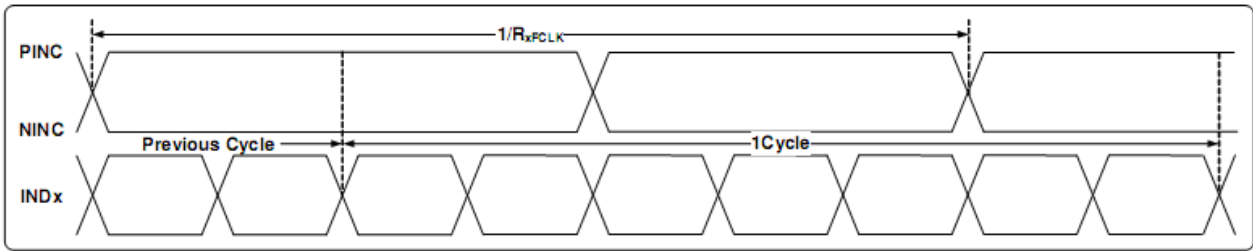

5.2 DC Electrical Characteristics

VDD=3.3V, AVDD=11V, AGND=GND=0V, Ta=25°C

Parameter	Symbol	Min	Typ	Max	Unit	Remark
Differential input high Threshold voltage	R_{XVTH}	-	-	+0.1	V	
Differential input Low Threshold voltage	R_{XVTL}	-0.1	-	-	V	
Input voltage range	R_{XVIN}	0	-	$V_{DD}-1.2+$ $ V_{ID} /2$	V	

Differential input common Mode voltage	R_{xVCM}	$ V_{ID} /2$	-	VDD-1.2	V	
Differential input voltage	$ V_{ID} $	0.2	v	0.6	V	
Differential input leakage Current	$R_{V_{XIZ}}$	-10	v	+10	μA	
LVDS Digital Operating Current	I_{ddlvds}	-	(15)	(30)	mA	Fclk=65MHz, VDD=3.3V
LVDS Digital Stand-by Current	I_{stlvds}	-	(10)	(50)	μA	Clock & all functions are stopped

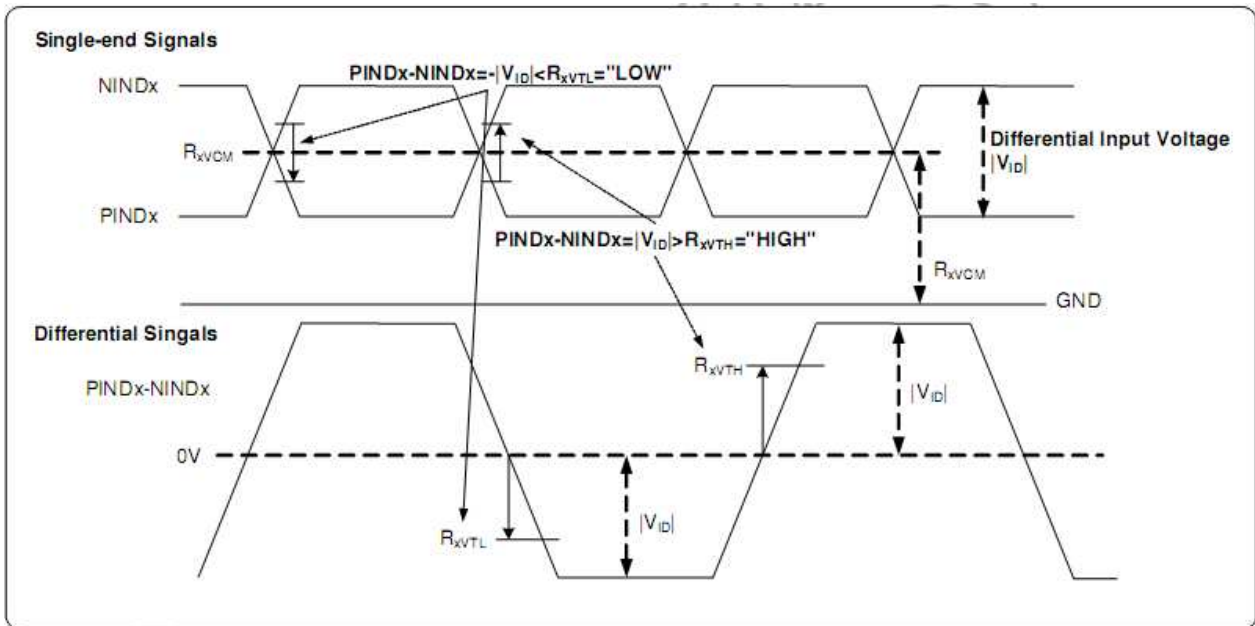

5.3 Timing

Parameter	Symbol	Min	Typ	Max	Unit	Remark
Clock frequency	fclk	40.8	51.2	67.2	MHz	Frame rate=60Hz
Horizontal display area	thd	1024			DCLK	
HS period time	th	1114	1344	1400	DCLK	
HS Blanking	thbp+thfp	90	320	376	DCLK	
Vertical display area	tvd	600			H	

VS period time	tv	610	635	800	H	
VS Blanking	tvbp+tvfp	10	35	200	H	

5.4 Data Input Format

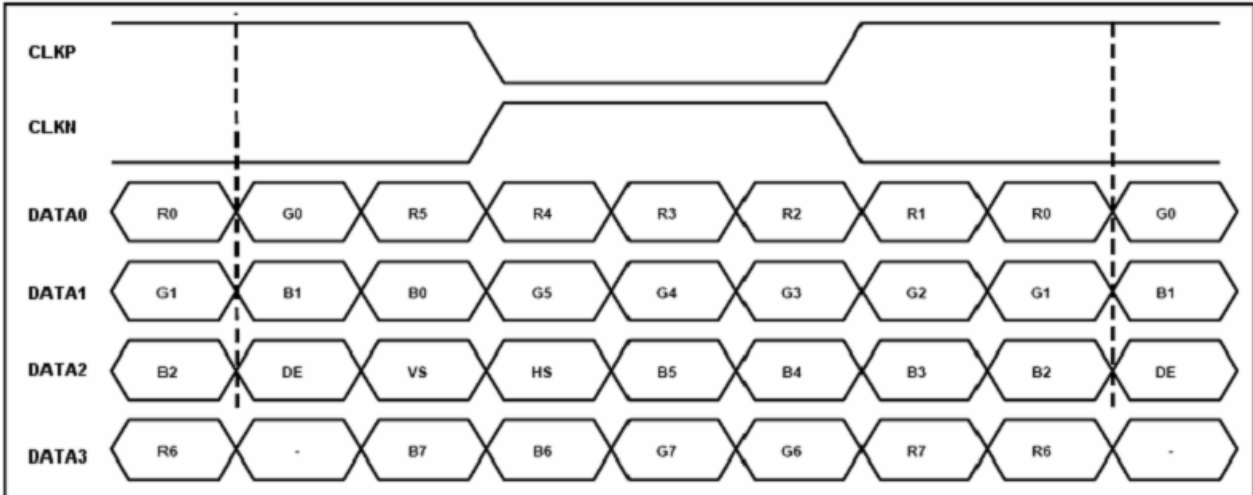

5.5 Input Clock and Data Timing Diagram

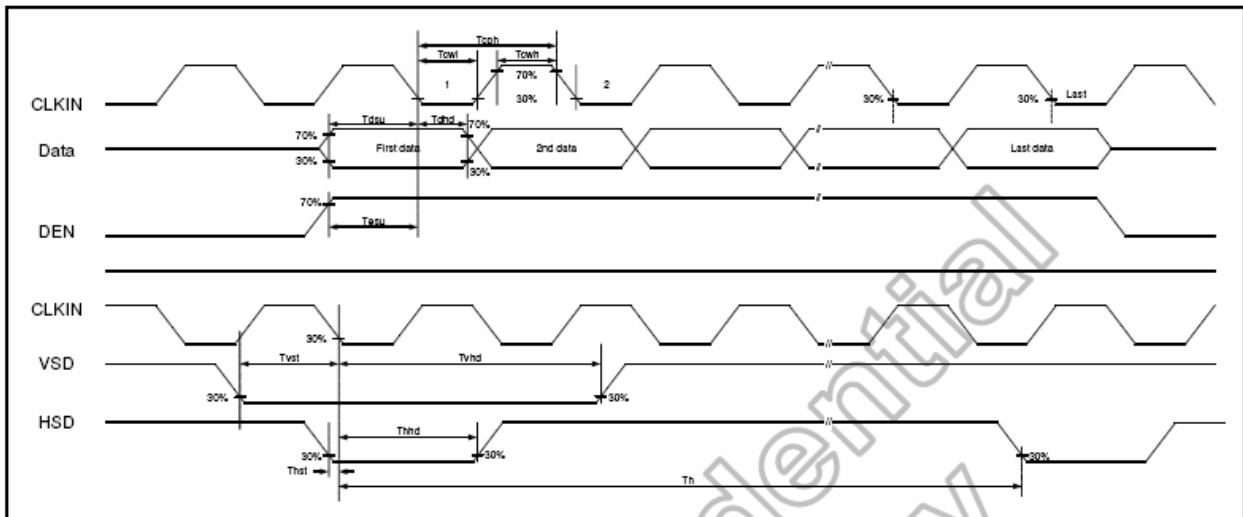

Optical Characteristics

6.1 TFT Optical Characteristics

Item	Symbol	Condition	Min	Typ	Max	Unit	Remark
View Angles	θT	$CR \geq 10$	60	70	-	Degree	Note 2
	θB		65	75	-		
	θL		65	75	-		
	θR		65	75	-		
Contrast Ratio	CR	$\theta=0^\circ$	400	500	-		Left/right 0° Top/bottom 5°
Response Time	T_{ON}	$25^\circ C$	-	20	30	ms	Note1 Note4
	T_{OFF}						
Chromaticity	White	x	0.260	0.310	0.360		Note5 Note1
		y	0.280	0.330	0.380		
	Red	x	0.539	0.539	0.589		
		y	0.298	0.298	0.348		
	Green	x	0.291	0.291	0.341		
		y	0.533	0.533	0.583		
	Blue	x	0.102	0.102	0.152		
		y	0.057	0.057	0.107		
Uniformity	U		70	75	-	%	Note1、 Note6
NTSC			45	50	-	%	
Luminance	L		280	320	-	cd/m^2	Note7

Test Conditions:

- $I_F = 20mA$ (one channel), the ambient temperature is $25^\circ C$.
- The test systems refer to Note 1 and Note 2.

Note 1: Definition of optical measurement system.

The optical characteristics should be measured in dark room. After 10 Minutes operation, the optical properties are measured at the center point of the LCD screen. All input terminals LCD panel must be ground when measuring the center area of the panel.

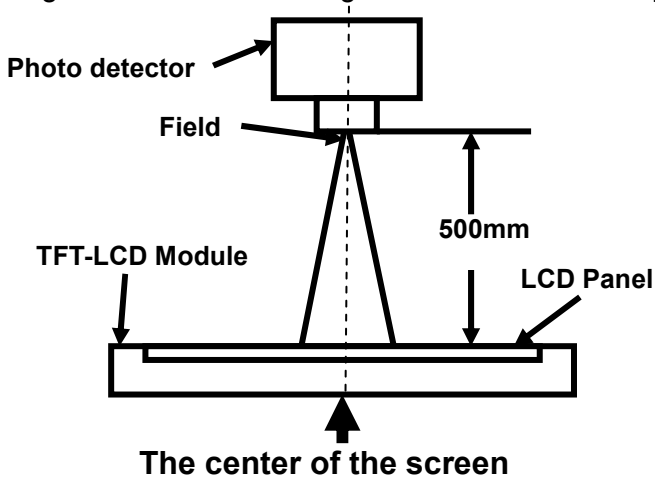

Item	Photo detector	Field
Contrast Ratio	BM-5A	1°
Luminance		
Lum Uniformity		
Chromaticity	SR-3A	
Response Time	TRD100	-

Note 2: Definition of viewing angle range and measurement system.

viewing angle is measured at the center point of the LCD by CONOSCOPE(ergo-80).

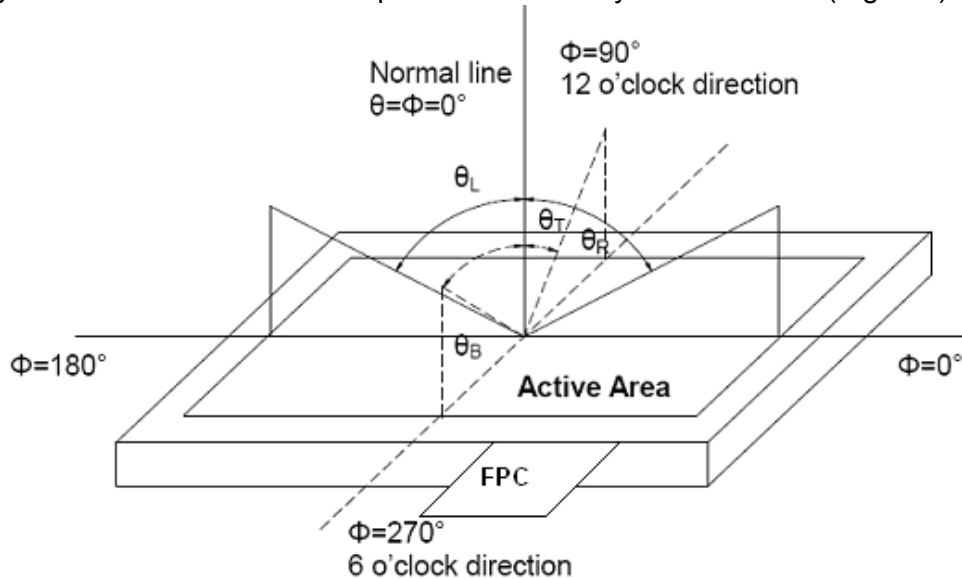

Note 3: Definition of contrast ratio

$$\text{Contrast ratio (CR)} = \frac{\text{Luminance measured when LCD is on the "White" state}}{\text{Luminance measured when LCD is on the "Black" state}}$$

“White state “: The state is that the LCD should drive by V_{white}.

“Black state”: The state is that the LCD should drive by V_{black}.

V_{white}: To be determined V_{black}: To be determined.

Note 4: Definition of Response time

The response time is defined as the LCD optical switching time interval between “White” state and “Black” state. Rise time (T_{ON}) is the time between photo detector output intensity changed from 90% to 10%. And fall time (T_{OFF}) is the time between photo detector output intensity changed from 10% to 90%.

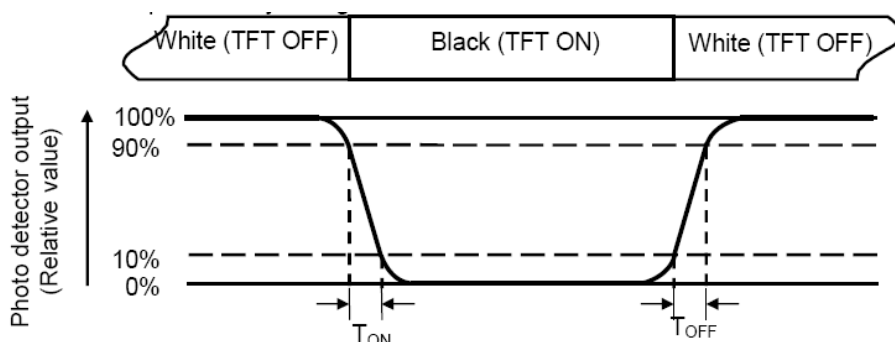

Note 5: Definition of color chromaticity (CIE1931)

Color coordinates measured at center point of LCD.

Note 6: Definition of Luminance Uniformity

Active area is divided into 9 measuring areas (Refer Fig. 2). Every measuring point is placed at the center of each measuring area.

$$\text{Luminance Uniformity (U)} = \text{Lmin} / \text{Lmax}$$

L-----Active area length W----- Active area width

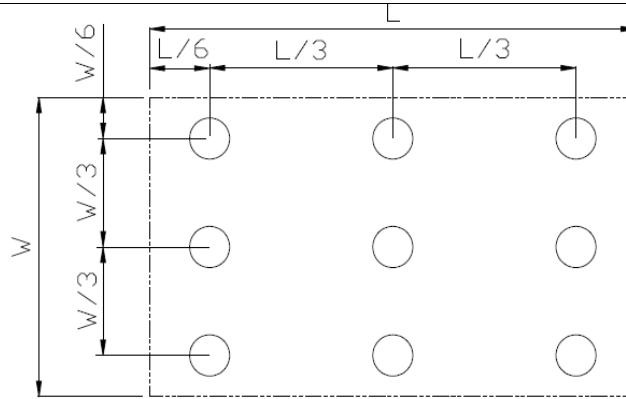

Lmax: The measured Maximum luminance of all measurement position.

Lmin: The measured Minimum luminance of all measurement position.

Note 7: Definition of Luminance:

Measure the luminance of white state at center point.

6.2 TP Optical Characteristics

(Ta = 25 °C)

No.	Item	Min.	Typ.	Max.	Unit	Remark
1	Transmission	86	88		%	Note 1
2	Reflectivity			4	%	Note 1, Note 2
3	HAZE			2	%	

Note1: Measuring equipments: DMS-501, PR-705. @550nm

Measuring condition:

- After stabilizing and leaving the panel alone at a given temperature for 30 min, the measurement should be executed,
- Measuring surroundings: a stable, windless and dark room,
- Measuring temperature: Ta=25°C,
- 30 min after lighting the back-light.

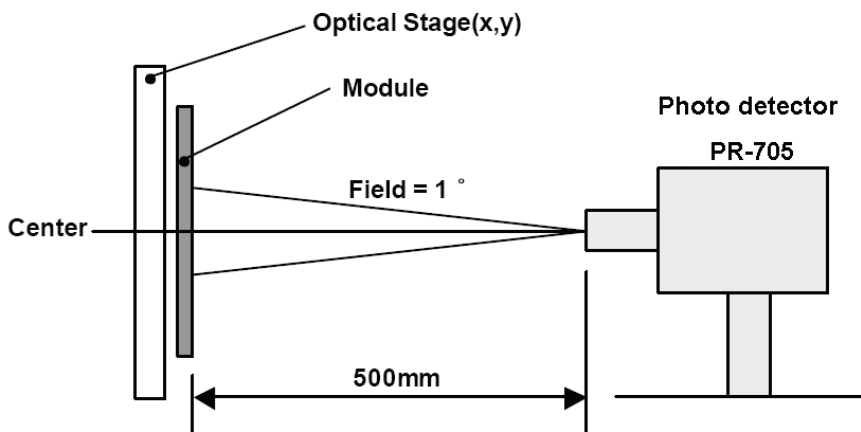

Note2: conform to National standard GB2410—80 /ASTM D1003—61(1997)

Reliability Test

No	Test Item	Condition	Remarks
1	High Temperature Operation	Ta = +70°C, 240 hours	Note1,Note6,Note7 IEC60068-2-1,GB2423.2
2	Low Temperature Operation	Ta = -20°C, 240 hours	Note1, Note7,IEC60068-2-1 GB2423.1
3	High Temperature Storage	Ta = +80°C, 240 hours	Note1, Note7,Note8 IEC60068-2-1 GB2423.2
4	Low Temperature Storage	Ta = -30°C, 240 hours	Note1, Note7,EC60068-2-1 GB2423.1
5	High Temperature & Humidity Storage	Ta=+65°C、RH=90%, 240 hours	Note1,Note3, Note4,Note7 IEC60068-2-78 GB/T2423.3
6	Thermal Shock/ Solder Joint Life Test	-30°C (30min) ⇔ 80°C (30min) ,Change Time:5min,100cycle	Note1,Note9 Start with cold temperature End with high temperature, IEC60068-2-14,GB2423.22
12	ESD	C=150pF、R=330Ω Air: ±8KV Contact:±8KV 5times (Environment:15°C~35°C, 30%~60%.86Kpa~106Kpa)	Note2,Note5, IEC61000-4-2 GB/T17626.2
13	Shock Test	Half Sine Wave 100G,6ms,±X,±Y,±Z 3times for each direction	Note2
14	Drop Test(package state)	Height:60cm, 1corner,3edges,6surfaces	Note2,IEC60068-2-32 GB/T2423.8

Notes:

1. The test result shall be evaluated after the sample has been left at room temperature and humidity for 2 hours without load. No condensation shall be accepted. The sample will not be accepted if appear these defects:

- 1).Air bubble in the LCD;
- 2).Seal leak
- 3).Non-display
- 4).missing segments
- 5).Glass crack
- 6).CR reduction >40%
- 7).IDD increase >100%
- 8).Brightness reduction >50%
- 9).Color coordinate tolerance >0.05

2. The samples of these tests will not be accepted if appear these defects:

- 1).Air bubble in the LCD;
- 2).Seal leak

- 3).Non-display
 - 4).missing segments
 - 5).Glass crack
3. Each test item applies for a test sample only once, The test sample can not be used again in any other test item.
- 4.For Damp Proof Test, Pure water(Resistance > 10MΩ) should be used.
- 5.In case of malfunction defect caused by ESD damage, if it would be recovered to normal state after resetting, it would be judge as a good part.
- 6 In the test of High Temperature Operation and High Temperature & Humidity Operation ,the operation temperature is the surface temperature of module
- 7 High Temperature Operation、 Low Temperature Operation、 High Temperature Storage、 Low Temperature Storage、 High Temperature & Humidity Operation、 High Temperature & Humidity Storage will be increased the test time to 1000hours in the same conditions to test out the ability of module, and we can not guarantee that the module will not fail during 1000hours.These items test only once
- 8.Thermal Shock will be changed the cycle to 1000cycles to test out the ability of module, and we can not guarantee that the module will not fail after the test. This item test only once

8 Mechanical Drawing

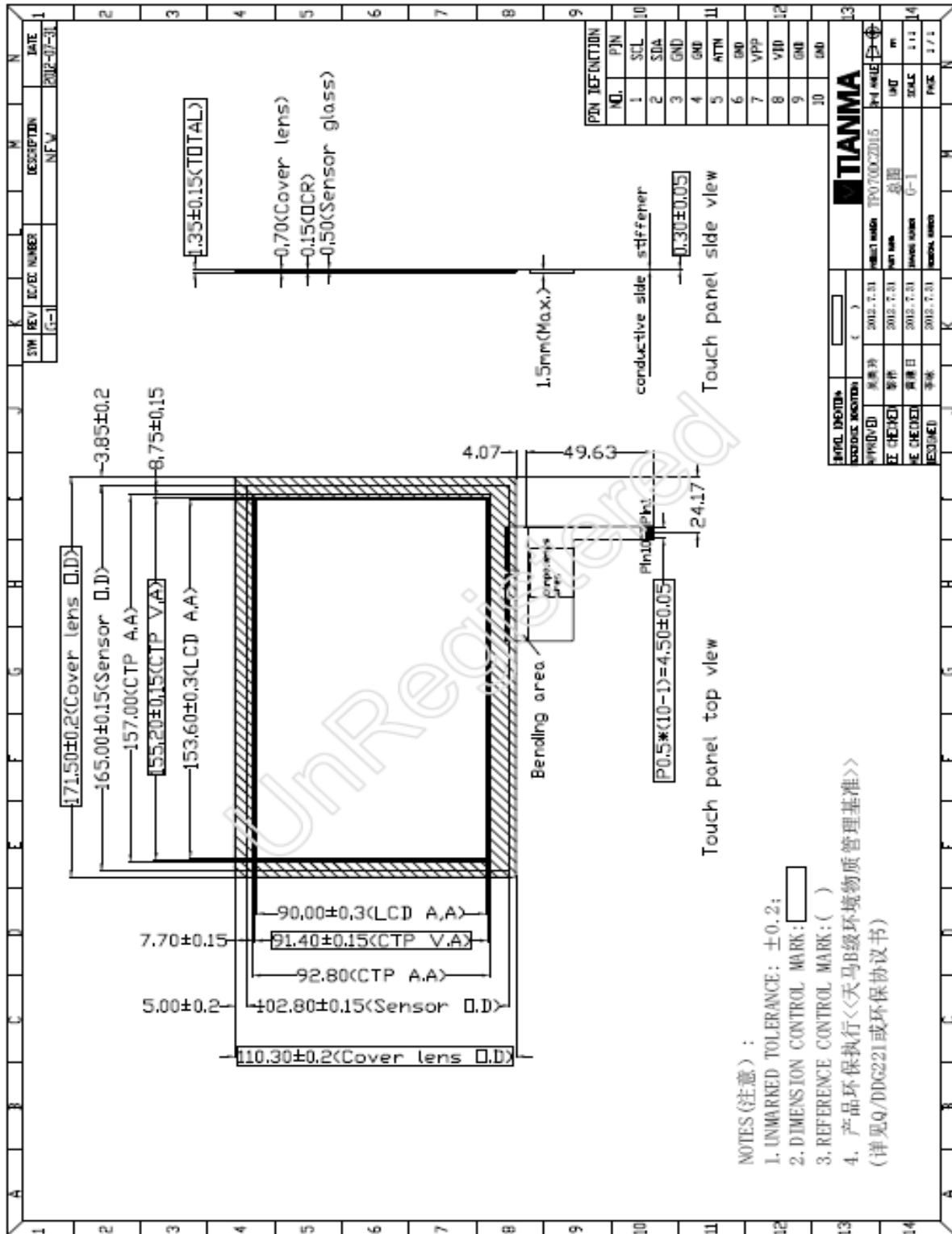

9. Product Inspection Criteria

9.1 Classification of defects

Major defects (MA): A major defect refers to a defect that may substantially degrade usability for product applications, including all functional defects (such as no display, abnormal display, open or missing segment, short circuit, missing component), outline dimension beyond the drawing, progressive defects and those affecting reliability.

Minor defects (MI): A minor defect refers to a defect which is not considered to be able to substantially degrade the product application or a defect that deviates from existing standards almost unrelated to the effective use of the product or its operation, such as black spot, white spot, bright spot, pinhole, black line, white line, contrast variation, glass defect, polarizer defect, etc.

9.2 Definition of inspection range

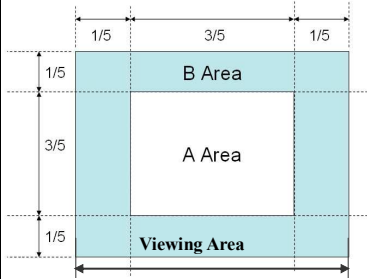
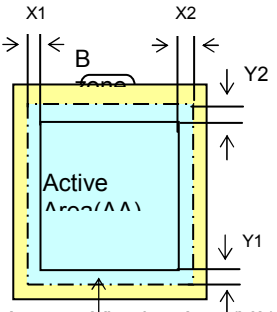
<p>For dot defect of TFT LCD which is not smaller than 3 inches, dividing three areas to make a judgment (according to figure 1).</p> <p>A area : center of viewing area B area : periphery of viewing area C area : Outside viewing area</p> <p>For other defects, dividing two areas to make a judgment (according figure 2).</p> <p>A zone : Inside Viewing area B zone : Outside Viewing area</p> <p>X1(A.A~V.A): 0mm X2(A.A~V.A): 0mm Y1(A.A~V.A): 0mm Y2(A.A~V.A): 0mm</p>	 <p>Figure 1</p>  <p>Figure 2</p>
--	--

9.3 Inspection items and general notes

General notes	<p>① Should any defects which are not specified in this standard happen, additional standard shall be determined by mutual agreement between customer and TIANMA.</p> <p>② Viewing area should be the area which TIANMA guarantees.</p> <p>③ Limit sample should be prior to this Inspection standard.</p> <p>④ Viewing judgment should be under static pattern.</p> <p>⑤ Inspection conditions Inspection distance: 250 mm (from the sample) Temperature : 25±5 °C Inspection angle : 45 degrees in 12 o'clock direction (all defects in viewing area should be inspected from this direction)</p>	
Inspection items	Pinhole, Bright spot, Black spot, White spot, Black line, White Line, Foreign particle, Bubble	The color of a small area is different from the remainder. The phenomenon doesn't change with voltage
	Contrast variation	The color of a small area is different from the remainder. The phenomenon changes with voltage
	Polarizer defect	Scratch, Dirt, Particle, Bubble on polarizer or between polarizer and glass
	Dot defect (TFT LCD)	The pixel appears bright or dark abnormally when display
	Functional defect	No display, Abnormal display, Open or missing segment, Short circuit, False viewing direction

	Glass defect	Glass crack, Shaved corner of glass, Surplus glass
	PCB defect	Components assembly defect

9.4 Outgoing Inspection level

Outgoing Inspection standard	Inspection conditions	Inspection				
		Min.	Max.	Unit	IL	AQL
Major Defects	See 9.3 general notes	See 9.5			II	0.65
Minor Defects	See 9.3 general notes	See 9.5			II	1.5

Note : Sampling standard conforms to GB2828

9.5 Inspection Items and Criteria

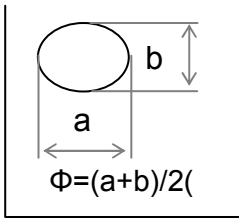
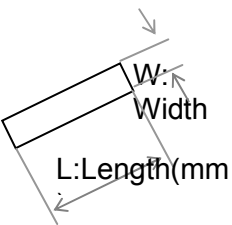
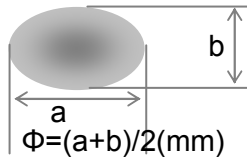
Inspection items			Judgment standard					
			Category		Acceptable number			
					A zone	B zone		
1	Black spot, White spot, Bright Spot, Pinhole, Foreign Particle, Particle in or on glass, Scratch on glass		A	$\Phi \leq 0.10$	Neglected			
			B	$0.10 < \Phi \leq 0.15$	2			
			C	$0.15 < \Phi \leq 0.20$	1			
			D	$0.20 < \Phi$	0			
			Total defective point(B,C)		3		Neglected	
2	Black line, White line, and Particle Between Polarizer and glass, Scratch on glass		A	$W \leq 0.01$	Neglected			
			B	$0.01 < W \leq 0.03$ $L \leq 3.0$	2			
			C	$0.03 < W \leq 0.05$ $L \leq 3.0$	1			
			D	$0.05 < W$	0			
			Total defective point(B,C)		3		Neglected	
3	Contrast variation		A	$\Phi \leq 0.2$	Neglected			
			B	$0.2 < \Phi \leq 0.3$	2			
			C	$0.3 < \Phi \leq 0.4$	1			
			D	$0.4 < \Phi$	0			
			Total defective point(B,C)		3		Neglected	
4	Dot defect (if TFT LCD is smaller than 3 inches)		LCD Class	Defect	A area	B area		
			A	Bright dot	1	Neglected		

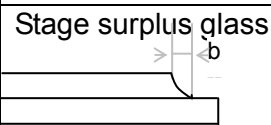
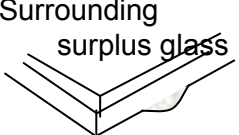
	used)			Dark dot	2	d	
				Total	2		
			B	Bright dot	2		
				Dark dot	3		
			Total	4			
		TFT LCD between 3~10.4 inches	LCD Class	Defect	A area	B area	Neglected
				A	Bright dot	1	
			Dark dot		1	2	
			Total		4		
			B	Bright dot	2	2	
Dark dot	2			3			
Total	6						
Notes: Bright dot: in R、G、B or dark display figure, the pixel appears bright. Dark dot: in R、G、B or white display figure, the pixel appears dark. Defect area must be less than an half size of the dot.							
5	Bubble inside cell		any size	none	none		
6	Polarizer defect (if Polarizer is used)	Scratch ,damage on polarizer, Particle on polarizer or between polarizer and glass.	Refer to item 1 and item 2.				
			Bubble, dent and convex	A	$\Phi \leq 0.3$	Neglected	Neglected
		B		$0.3 < \Phi \leq 0.7$	2		
		C		$0.7 < \Phi$	0		
7	Surplus glass	Stage surplus glass	 $b \leq 0.3\text{mm}$				
		Surrounding surplus glass	 Should not influence outline dimension and assembling.				
8	Open segment or open common	Not permitted					
9	Short circuit	Not permitted					
10	False viewing direction	Not permitted					
11	Contrast ratio uneven	According to the limit specimen					
12	Crosstalk	According to the limit specimen					
13	Black /White spot(display)	Refer to item 1					
14	Black /White line(display)	Refer to item 2					

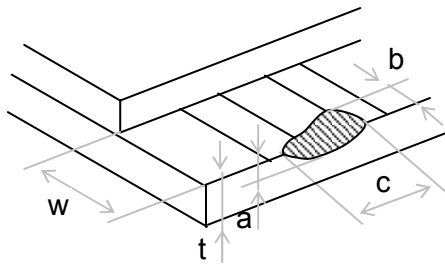
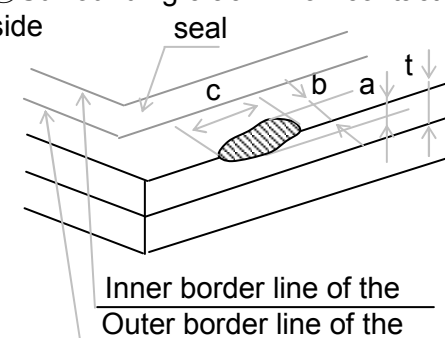
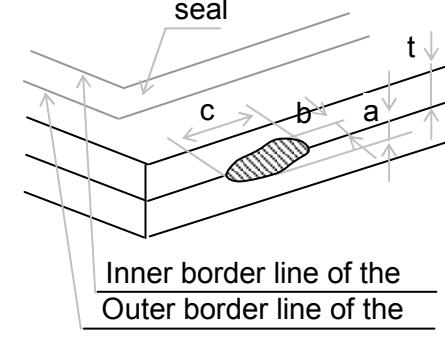
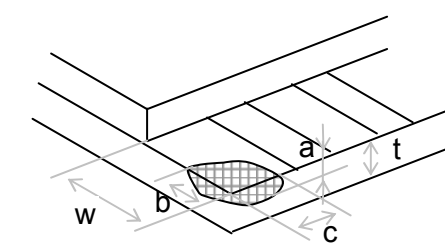
Inspection items		Judgment standard		Acceptable number	
		Category(application: B zone)			
15	Glass defect crack	①The front of lead terminals		A $a \leq t, b \leq 1/5W, c \leq 3\text{mm}$	Max.3 defects allowed
			B Crack at two sides of lead terminals should not cover patterns and alignment mark		
		②Surrounding crack—non-contact side		$b < \text{Inner border line of the seal}$	
		③ Surrounding crack— contact side		$b < \text{Outer border line of the seal}$	
	④Corner		A $a \leq t, b \leq 3.0, c \leq 3.0$		
			B Glass crack should not cover patterns u and alignment mark and patterns.		

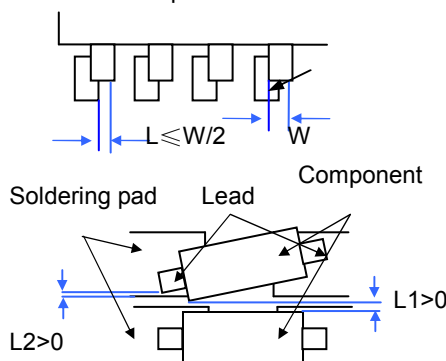
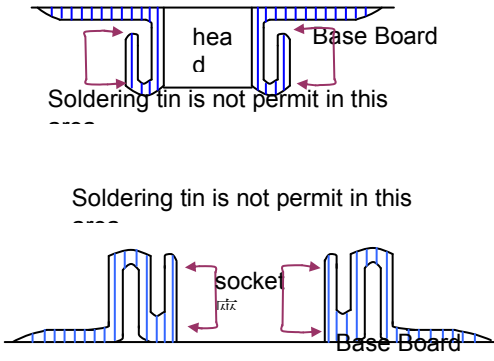
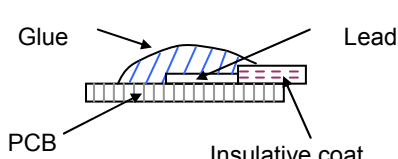
Inspection items		Judgment standard	
		Category(application: B zone)	
16	PCB defect	<p>Component soldering: No cold soldering · short · open circuit · burr · tin ball The flat encapsulation component position deviation must be less than 1/3 width of the pin (Pic.1) ; the sheet component deviation: Pin deviates from the pad and contact with the near components is not permitted (Pic.2)</p>	<p>Component</p> 
	PCB defect	<p>lead defect: The lead lack must be less than 1/3 of its width; The lead burr must be less than 1/3 of the seam; Impurities connect with the near leads is not permitted</p>	
	PCB defect	<p>Connector soldering: Soldering tin is at contact position of the plug and socket is not permitted No foundation is scald Serious cave distortion on plug and socket contact pin is not permitted</p>	
	PCB defect	<p>Glue on root of the speaker receiver and motor lead: The insulative coat of the lead must join into the PCB; the protected glue must envelop to the insulative coat.</p>	

10. Precautions for Use of LCD Modules

10.1 Handling Precautions

- 10.1.1 The display panel is made of glass. Do not subject it to a mechanical shock by dropping it from a high place, etc.
- 10.1.2 If the display panel is damaged and the liquid crystal substance inside it leaks out, be sure not to get any in your mouth, if the substance comes into contact with your skin or clothes, promptly wash it off using soap and water.
- 10.1.3 Do not apply excessive force to the display surface or the adjoining areas since this may cause the color tone to vary.
- 10.1.4 The polarizer covering the display surface of the LCD module is soft and easily scratched. Handle this polarizer carefully.
- 10.1.5 If the display surface is contaminated, breathe on the surface and gently wipe it with a soft dry cloth. If still not completely clear, moisten cloth with one of the following solvents:
- Isopropyl alcohol
 - Ethyl alcohol
- Solvents other than those mentioned above may damage the polarizer.
Especially, do not use the following:
- Water
 - Ketone
 - Aromatic solvents
- 10.1.6 Do not attempt to disassemble the LCD Module.
- 10.1.7 If the logic circuit power is off, do not apply the input signals.
- 10.1.8 To prevent destruction of the elements by static electricity, be careful to maintain an optimum work environment.
- a. Be sure to ground the body when handling the LCD Modules.
 - b. Tools required for assembly, such as soldering irons, must be properly ground.
 - c. To reduce the amount of static electricity generated, do not conduct assembly and other work under dry conditions.
 - d. The LCD Module is coated with a film to protect the display surface. Be care when peeling off this protective film since static electricity may be generated.

10.2 Storage precautions

10.2.1 When storing the LCD modules, avoid exposure to direct sunlight or to the light of fluorescent lamps.

10.2.2 The LCD modules should be stored under the storage temperature range. If the LCD modules will be stored for a long time, the recommend condition is:

Temperature : 0°C ~ 40°C

Relatively humidity: ≤80%

10.2.3 The LCD modules should be stored in the room without acid, alkali and harmful gas.

10.3 The LCD modules should be no falling and violent shocking during transportation, and also should avoid excessive press, water, damp and sunshine.