

MODEL NO : TM035PDHG03

MODEL VERSION: 00

SPEC VERSION : V2.6

ISSUED DATE: 2016.07.08

- Preliminary Specification
- Final Product Specification

Customer : _____

Approved by	Notes

TIANMA Confirmed :

Prepared by	Checked by	Approved by
Lynn. Fu 2016.07.08	Flexi. Tan 2016.07.08	Qing.F.en 2016.07.08

This technical specification is subjected to change without notice

Table of Contents

Table of Contents.....	2
Record of Revision.....	3
1 General Specifications.....	4
2 Input/Output Terminals.....	5
3 Absolute Maximum Ratings.....	7
4 Electrical Characteristics.....	8
5 Timing Chart.....	9
6 Optical Characteristics.....	25
7 Environmental / Reliability Test.....	28
8 Mechanical Drawing.....	29
9 Packing Drawing.....	30
10 Precautions for Use of LCD Modules.....	31

TIANMA CONFIDENTIAL

Record of Revision

Rev	Issued Date	Description	Editor
1.0	2014-04-10	Preliminary Specification Release	Wenlong Liu
1.1	2014-04-28	Modify the mistake of RA test requirements	Yihua liang
2.0	2014-09-05	Final Product Release. change mechanical drawing, optical characteristics	Wenlong Liu
2.1	2014-09-30	Add Packing Drawing	Wenlong Liu
2.2	2015-08-31	Update Packing Drawing and VCI MIN. value	wuxuan
2.3	2015-10-26	Modify SPI Interface Timing Characteristic (Page16 17), update packing	Lynn. Fu
2.4	2015-12-04	Add lifetime and update packing	Lynn. Fu
2.5	2016-02-16	Update ESD condition	Lynn.Fu
2.6	2016-07-08	Update page 26	Lynn Fu

1 General Specifications

	Feature	Spec
Display Spec.	Size	3.5 inch
	Resolution	320(RGB) x 480
	Technology Type	a-Si
	Pixel Configuration	R.G.B. Vertical Stripe
	Pixel pitch(mm)	0.153(H)x0.153(V)
	Display Mode	TM with Normally White
	Surface Treatment	HC
	Viewing Direction	6 o'clock
	Gray Scale Inversion Direction	12 o'clock
Mechanical Characteristics	LCM (W x H x D) (mm)	55.26 x 84.69 x 2.2
	Active Area(mm)	48.96x73.44
	With /Without TSP	Without TSP
	Matching Connection Type	ZIF
	LED Numbers	6 LEDs
	Weight (g)	21.0
Electrical Characteristics	Interface	MCU+RGB+SPI
	Color Depth	65K/262K
	Driver IC	ILI9488

Note 1: Viewing direction for best image quality is different from TFT definition. There is a 180 degree shift.

Note 2: Requirements on Environmental Protection: Q/S0002+HF

Note 3: LCM weight tolerance: $\pm 5\%$

2 Input/Output Terminals

Pin No.	Symbol	I/O	Function	Remark
1	FLM	O	Output a frame head pulse signal If no used, please open this pin	
2	GND	P	Ground	
3	ENABLE	I	Data enable signal in RGB mode If no used, please fix this pin at GND level	
4	DOTCLK	I	Pixel clock signal in RGB mode If no used, please connect this pin to GND	
5	VSYNC	I	Vertical sync. signal in RGB mode If no used, please connect this pin to GND	
6	GND	P	Ground	
7	HSYNC	I	Horizontal sync, signal in RGB mode If no used, please connect this pin to GND	
8	IM0	I	MPU system interface mode select	
9	IM1	I	MPU system interface mode select	
10	IM2	I	MPU system interface mode select	
11	IOVCC	p	IO POWER	
12	VCC	P	Analog POWER	
13	SDI	I/O	Serial data in/out pin in DBI Type C 9bit mode Serial data input pin in DBI Type B 8bit mode If no used, please connect this pin to GND	
14	SDO	O	Serial data output pin If no used, leave this pin open	
15	DB17	I/O	Data Bus	
16	DB16	I/O	Data Bus	
17	DB15	I/O	Data Bus	
18	DB14	I/O	Data Bus	
19	DB13	I/O	Data Bus	
20	DB12	I/O	Data Bus	
21	DB11	I/O	Data Bus	
22	DB10	I/O	Data Bus	
23	DB9	I/O	Data Bus	
24	DB8	I/O	Data Bus	
25	DB7	I/O	Data Bus	
26	DB6	I/O	Data Bus	
27	DB5	I/O	Data Bus	

The information contained herein is the exclusive property of TIANMA MICRO-ELECTRONICS Corporation and shall not be distributed, reproduced, or disclosed in whole or in part without prior written permission of TIANMA MICRO-ELECTRONICS Corporation.

28	DB4	I/O	Data Bus	
29	DB3	I/O	Data Bus	
30	DB2	I/O	Data Bus	
31	DB1	I/O	Data Bus	
32	DB0	I/O	Data Bus	
33	RESET	I	Reset pin	
34	RD	I	Read strobe signal If no used, please connect this pin to IOVCC	
35	WR/SCL	I	(WR) Write data enable pin in DBI Type B (SCL) Write data enable pin in DBI Type C If no used, please connect this pin to IOVCC	
36	RS	I	Data/command selection pin If no used, please connect this pin to IOVCC	
37	CS	I	Chip select signal If no used, please connect this pin to IOVCC	
38	LEDK6	P	LED CATHODE	
39	LEDK5	P	LED CATHODE	
40	LEDK4	P	LED CATHODE	
41	LEDK3	P	LED CATHODE	
42	LEDK2	P	LED CATHODE	
43	LEDK1	P	LED CATHODE	
44	LEDA	P	LED ANODE	
45	LCM_ID	O	Customer requirement: 1.8V	

Note1: I/O definition: I----Input O---Output P----Power/ Ground NC---Not Connected

IM2	IM1	IM0	Interface	WR/SCL	DATA Bus use	
					Command/Paramant	GRAM
0	0	0	DBI TYPE-B 18-bit (DB_EN='0')	WR	DB7-DB0	DB17-DB0:18bits Data
0	0	1	DBI TYPE-B 9-bit	WR	DB7-DB0	DB8-DB0:9bits Data
0	1	0	DBI TYPE-B 16-bit	WR	DB7-DB0	DB15-DB0:16bits Data
0	1	1	DBI TYPE-B 8-bit	WR	DB7-DB0	DB7-DB0:8bits Data
1	0	1	DBI TYPE-C Option 1(3 wire)	SCL	SDA/SDO	
1	1	1	DBI TYPE-C Option 3(4 wire)	SCL	SDA/SDO	

Table 2.1 System interface select

3 Absolute Maximum Ratings

GND=0V

Item	Symbol	MIN	MAX	Unit	Remark
Power Voltage	VCI	-0.3	3.3	V	Note1
Logic supply voltage	IOVCC	-0.3	3.3	V	
Logic Input voltage	RESET,CSX,SCL, SDA,D/CX	-0.3	IOVCC+0.3	V	
Operating Temperature	Top	-20	70	°C	
Storage Temperature	Tst	-30	80	°C	
Relative Humidity Note2	RH	--	≤95	%	Ta≤40°C
		--	≤85	%	40°C < Ta ≤ 50°C
		--	≤55	%	50°C < Ta ≤ 60°C
		--	≤36	%	60°C < Ta ≤ 70°C
		--	≤24	%	70°C < Ta ≤ 80°C
Absolute Humidity	AH	--	≤70	g/m ³	Ta > 70°C

Table 3.1 Absolute Maximum Ratings

Note1: Input voltage include DB0~DB17, Dotclk, Hsync, Vsync, Enable,RESET,CS,RD,WR/SCL,LCM_ID etc(For your reference)

Note2: Ta means the ambient temperature.
It is necessary to limit the relative humidity to the specified temperature range.
Condensation on the module is not allowed.

4 Electrical Characteristics

4.1 LCD module

Ta=25°C

Item	Symbol	MIN	TYP	MAX	Unit	Remark	
Logic Signal Input /Output Voltage	IOVCC	1.65	1.8	3.3	V		
Power Supply Voltage	VCI	2.65	2.8	3.3	V		
Input Signal Voltage	High Level	VIH	0.7*IOVCC	-	IOVCC	V	RESET,CSX,SCL,SDA,D/CX
	Low Level	VIL	-0.3	-	0.3*IOVCC		
Output Signal Voltage	High Level	VOH	0.8*IOVCC	-	IOVCC	V	
	Low Level	VOL	0	-	0.2*IOVCC	V	
(Panel+LSI) Power Consumption	Black Mode	-	34.2	-	mW		
	Sleeping Mode	-	2.4	-	mW		

Table 4.1 LCD module electrical characteristics

4.2 Backlight Unit

Ta=25°C

Item	Symbol	Min	Typ	Max	Unit	Remark
Forward Current	I _F	-	20	-	mA	1 LED
Forward Voltage	V _F	-	3.2	-	V	1 LED
Backlight Power Consumption	W _{BL}	-	384	-	mW	6 LEDs in parallel
LED lifetime			30,000		hrs	

Note1: Figure below shows the connection of backlight LED.

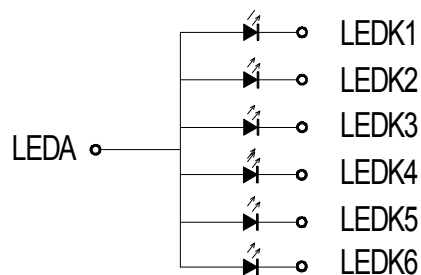
 Note 2: 1LED: V_F =3.2V I_F =20mA

 Note 3: : I_F is defined for one LED.

Circuit Diagram

Optical performance should be evaluated at Ta=25°C only.

If LED is driven by high current, high ambient temperature & humidity condition. The life time of LED will be reduced. Operating life means brightness goes down to 50% initial brightness. Typical operating life time is estimated data.

The information contained herein is the exclusive property of TIANMA MICRO-ELECTRONICS Corporation and shall not be distributed, reproduced, or disclosed in whole or in part without prior written permission of TIANMA MICRO-ELECTRONICS Corporation.

4.3 Block Diagram

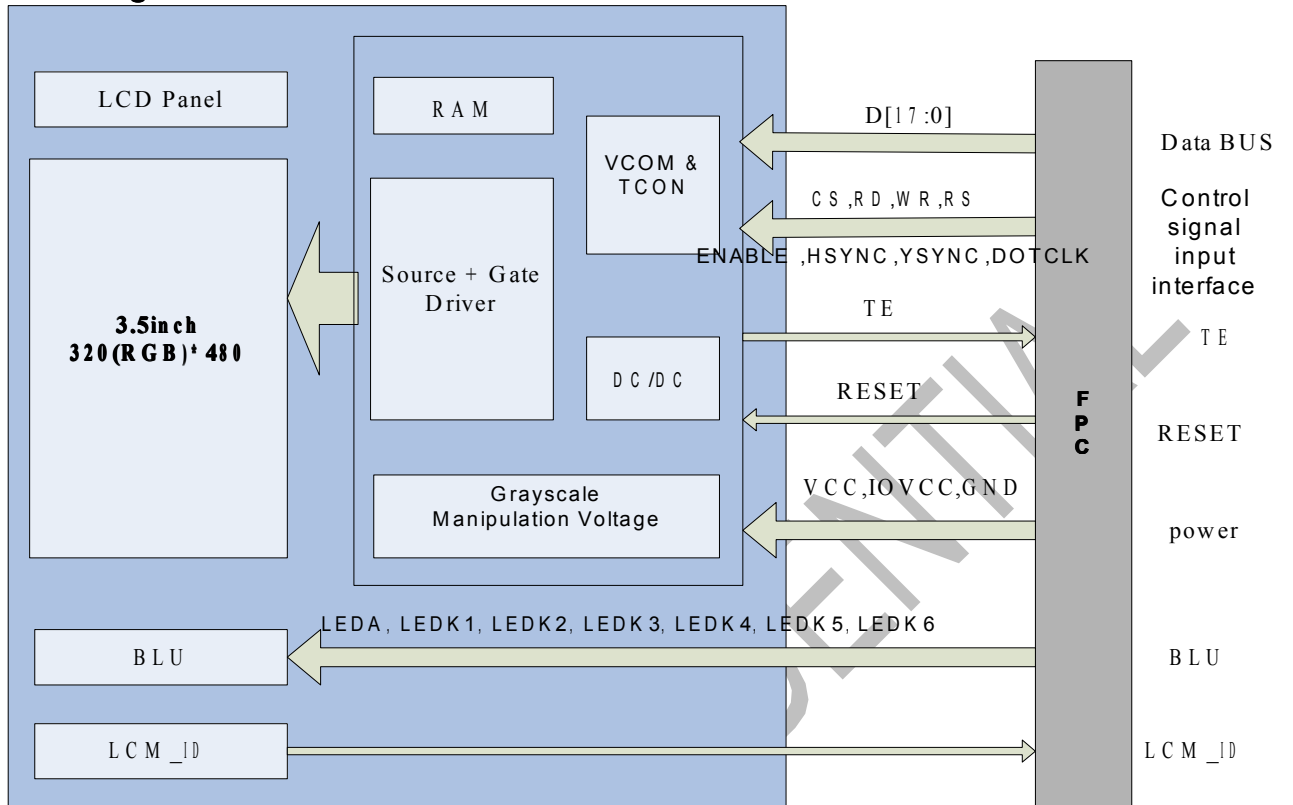

5 Timing Chart

5.1 DBI Type B

5.1.1 DBI Type B Timing Characteristic

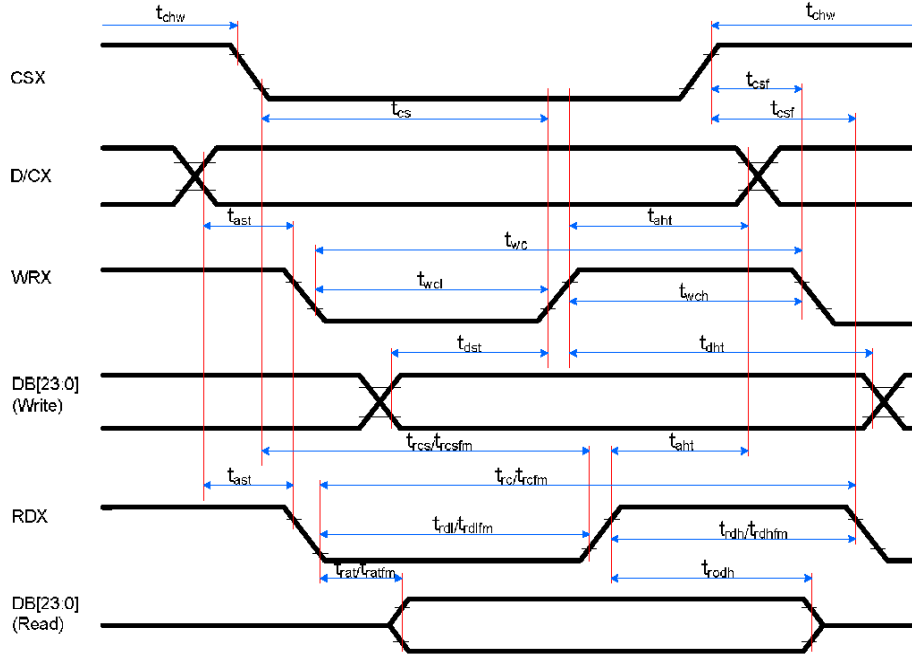

Signal	Symbol	Parameter	min	max	Unit	Description
DCX	t_{ast}	Address setup time	0	-	ns	-
	t_{ah}	Address hold time (Write/Read)	0	-	ns	-
CSX	t_{chw}	CSX "H" pulse width	0	-	ns	-
	t_{cs}	Chip Select setup time (Write)	15	-	ns	-
	t_{rcs}	Chip Select setup time (Read ID)	45	-	ns	-
	t_{rcsfm}	Chip Select setup time (Read FM)	355	-	ns	-
	t_{csf}	Chip Select Wait time (Write/Read)	0	-	ns	-
WRX	t_{wc}	Write cycle	40	-	ns	-
	t_{wrh}	Write Control pulse H duration	15	-	ns	-
	t_{wrl}	Write Control pulse L duration	15	-	ns	-
RDX (FM)	t_{rcfm}	Read Cycle (FM)	450	-	ns	When read from Frame Memory
	t_{rdhfm}	Read Control H duration (FM)	90	-	ns	
	t_{rdlfm}	Read Control L duration (FM)	355	-	ns	
RDX (ID)	t_{rc}	Read cycle (ID)	160	-	ns	When read ID data
	t_{rdh}	Read Control pulse H duration	90	-	ns	
	t_{rdl}	Read Control pulse L duration	45	-	ns	
DB [23:0], DB [17:0], DB [15:0], DB [8:0], DB [7:0]	t_{dst}	Write data setup time	10	-	ns	For maximum, CL=30pF For minimum, CL=8pF
	t_{dht}	Write data hold time	10	-	ns	
	t_{rat}	Read access time	-	40	ns	
	t_{ratfm}	Read access time	-	340	ns	
	t_{rod}	Read output disable time	20	80	ns	

The information contained herein is the exclusive property of TIANMA MICRO-ELECTRONICS Corporation and shall not be distributed, reproduced, or disclosed in whole or in part without prior written permission of TIANMA MICRO-ELECTRONICS Corporation.

Notes:

1. $T_a = -30$ to 70 °C, $IOVCC = 1.65V$ to $3.3V$, $VCI = 2.5V$ to $3.3V$, $AGND = DGND = 0V$
2. Logic high and low levels are specified as 30% and 70% of $IOVCC$ for input signals.
3. Input signal rising time and falling time:

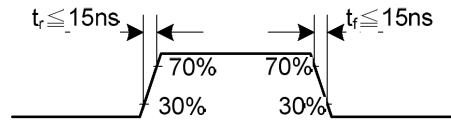

4. The CSX timing:

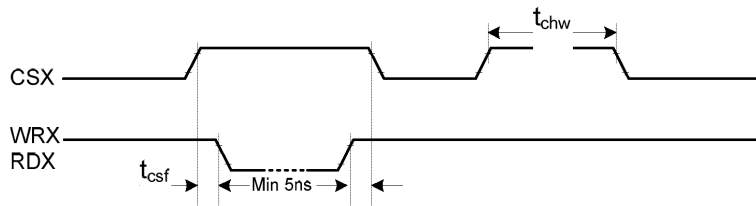

5. The Write to Read or the Read to Write timing:

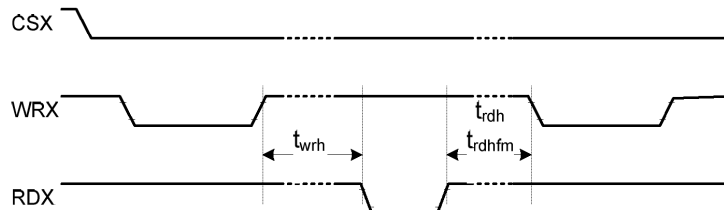

5.1.2 DBI Type B Data Bus

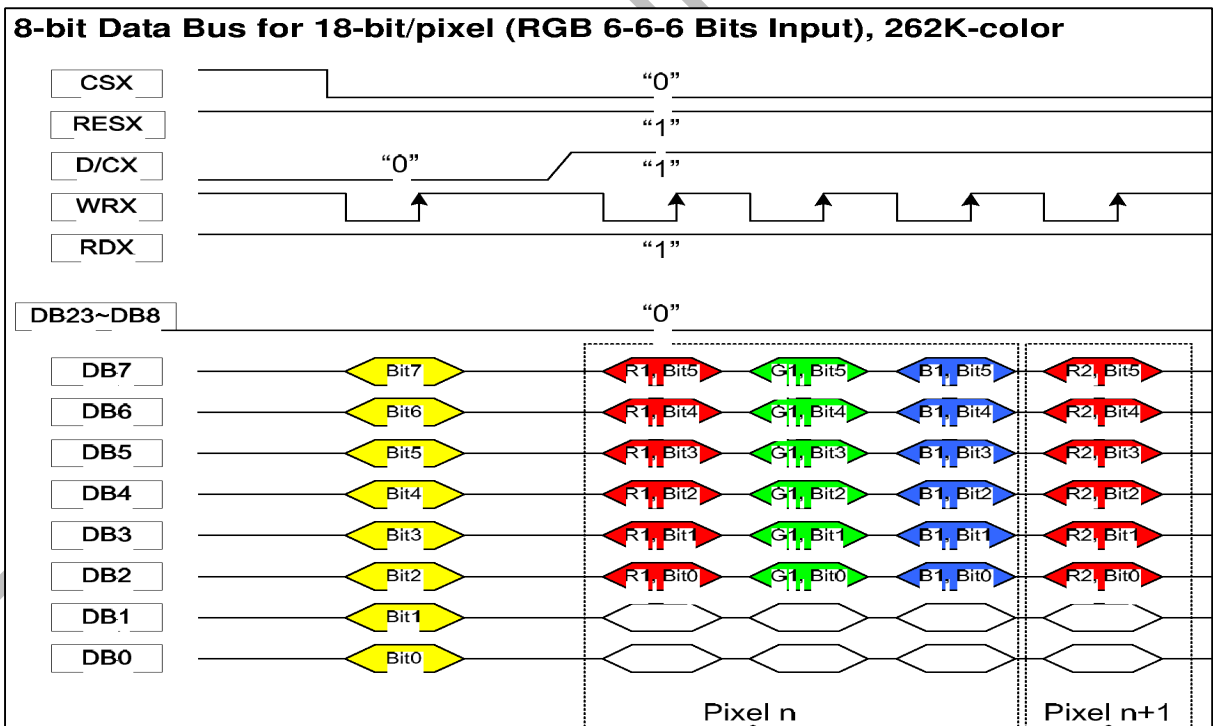
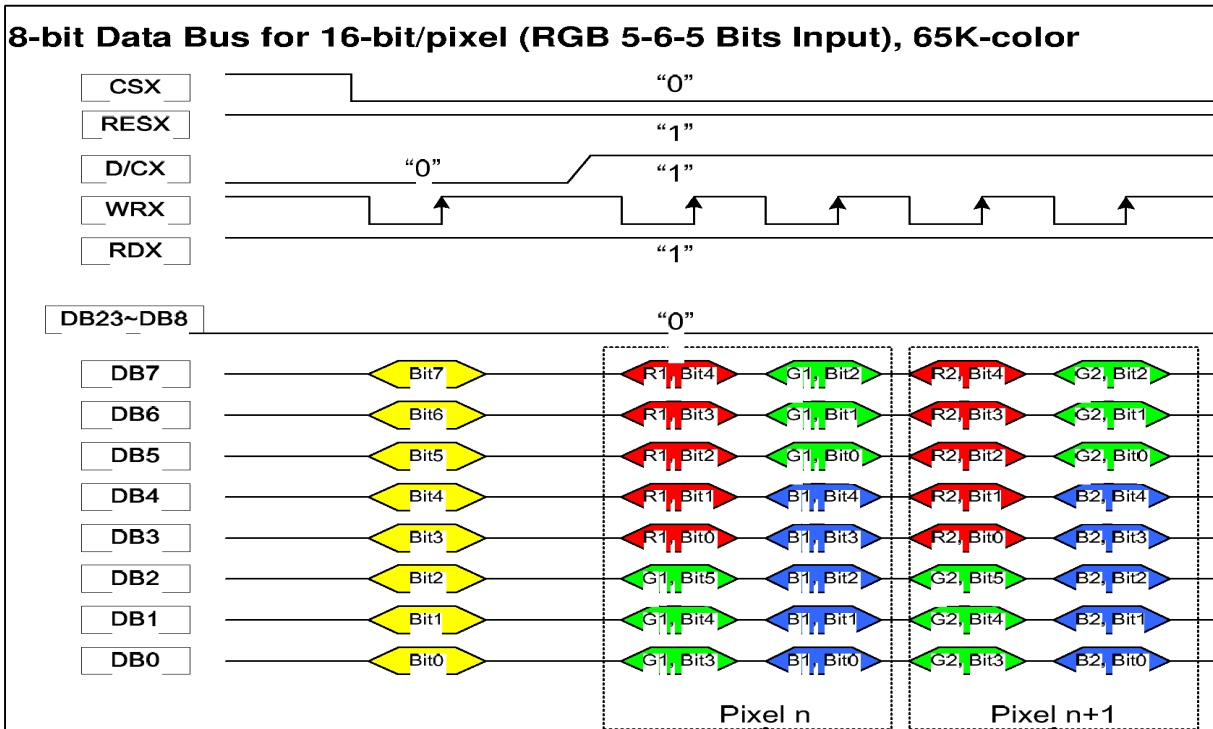

The information contained herein is the exclusive property of TIANMA MICRO-ELECTRONICS Corporation and shall not be distributed, reproduced, or disclosed in whole or in part without prior written permission of TIANMA MICRO-ELECTRONICS Corporation.

9-bit Data Bus for 18-bit/pixel (RGB 6-6-6 Bits Input), 262K-color

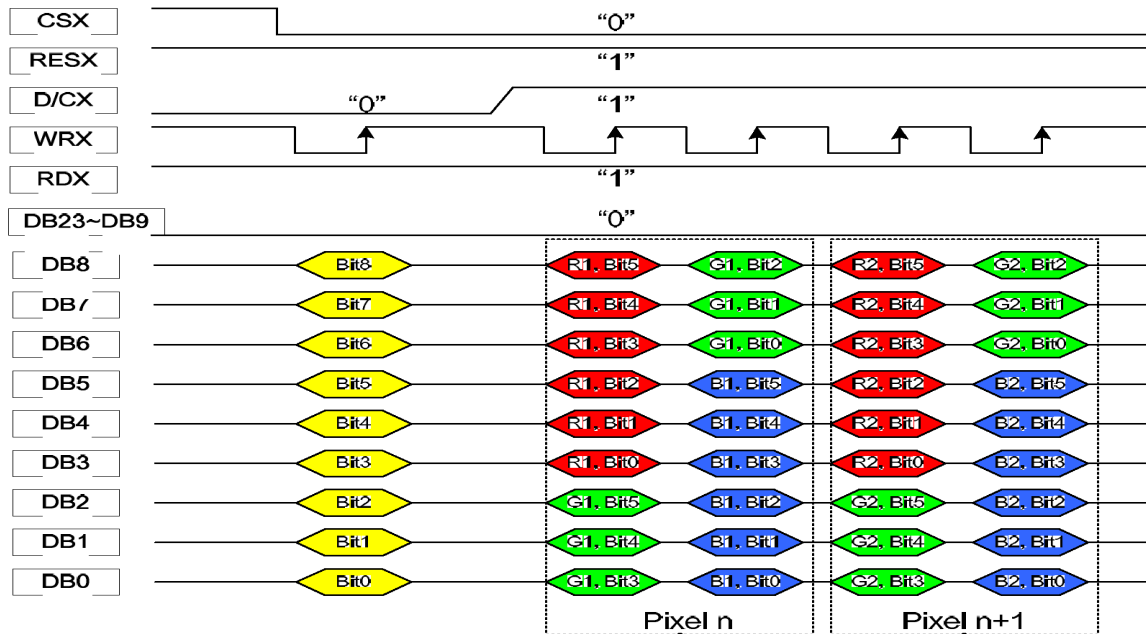

16-bit Data Bus for 16-bit/pixel (RGB 5-6-5 Bits Input), 65K-color

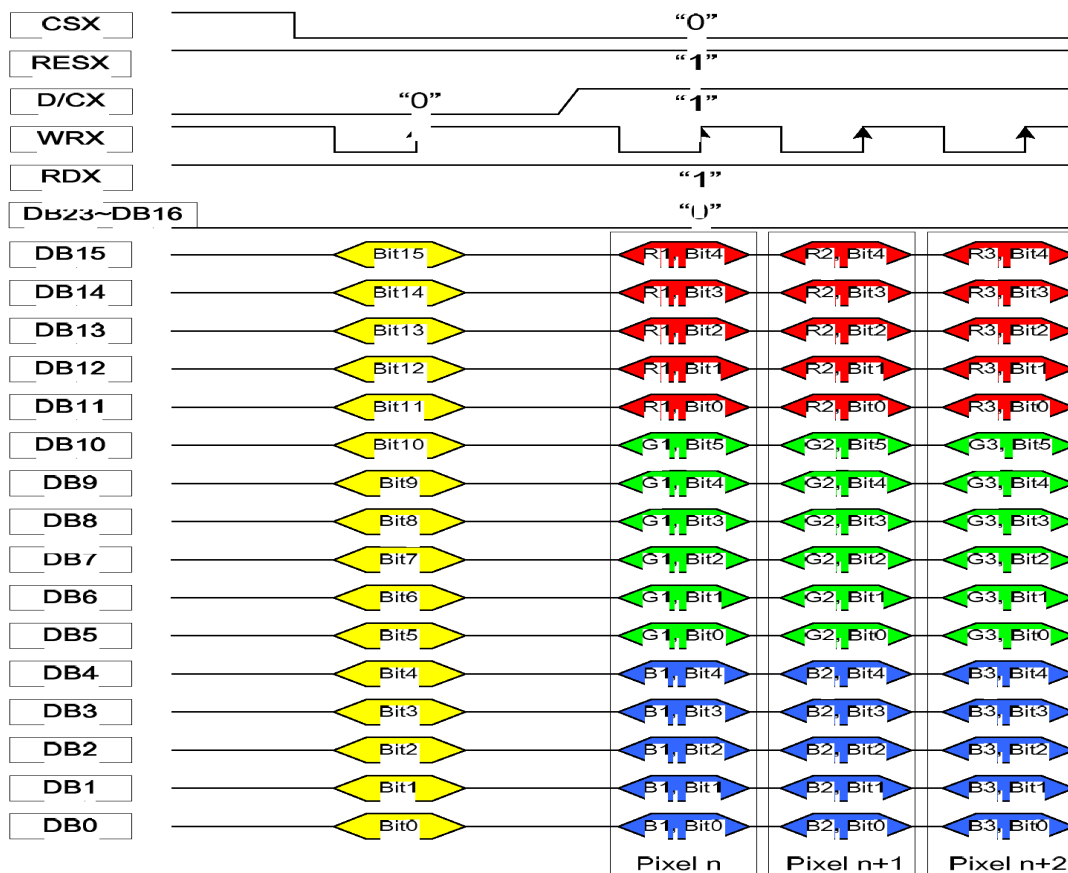

16-bit Data Bus for 18-bit/pixel (RGB 6-6-6 Bits Input), 262K-color

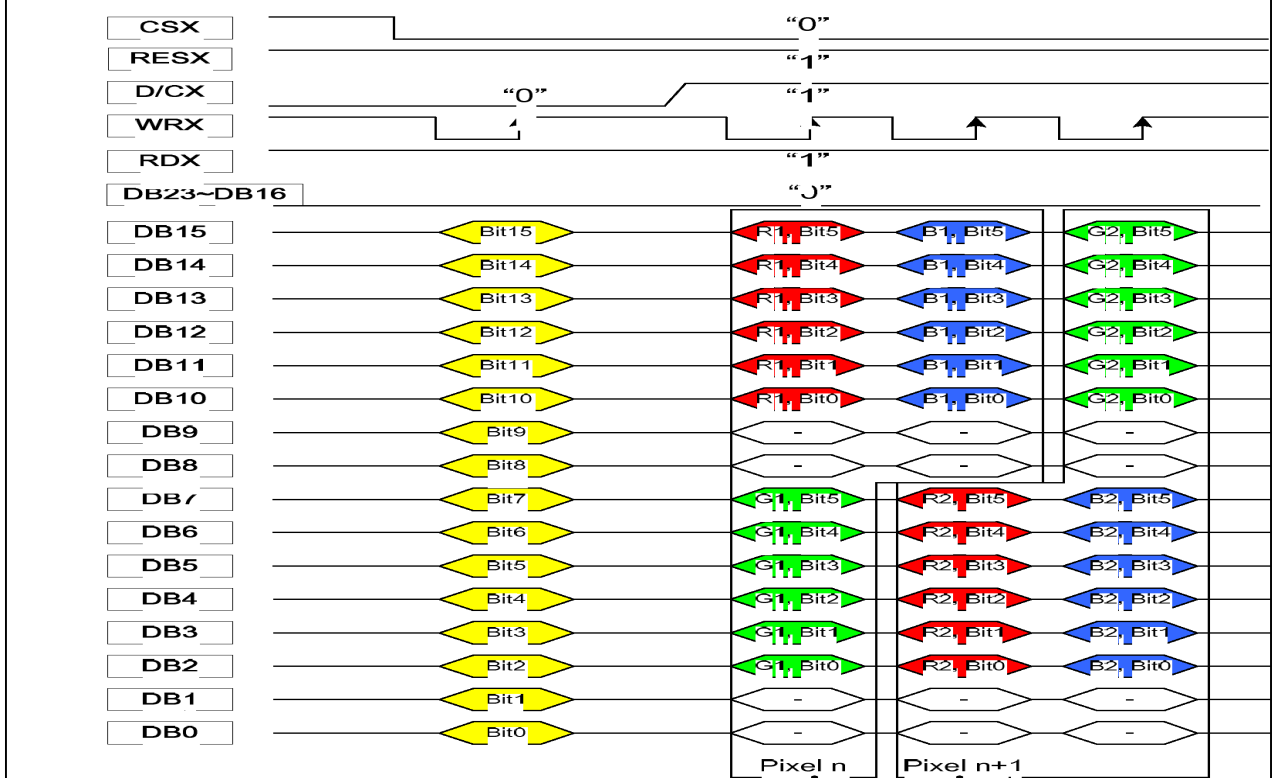

18-bit Data Bus for 18-bit/pixel (RGB 6-6-6 Bits Input), 262K-color

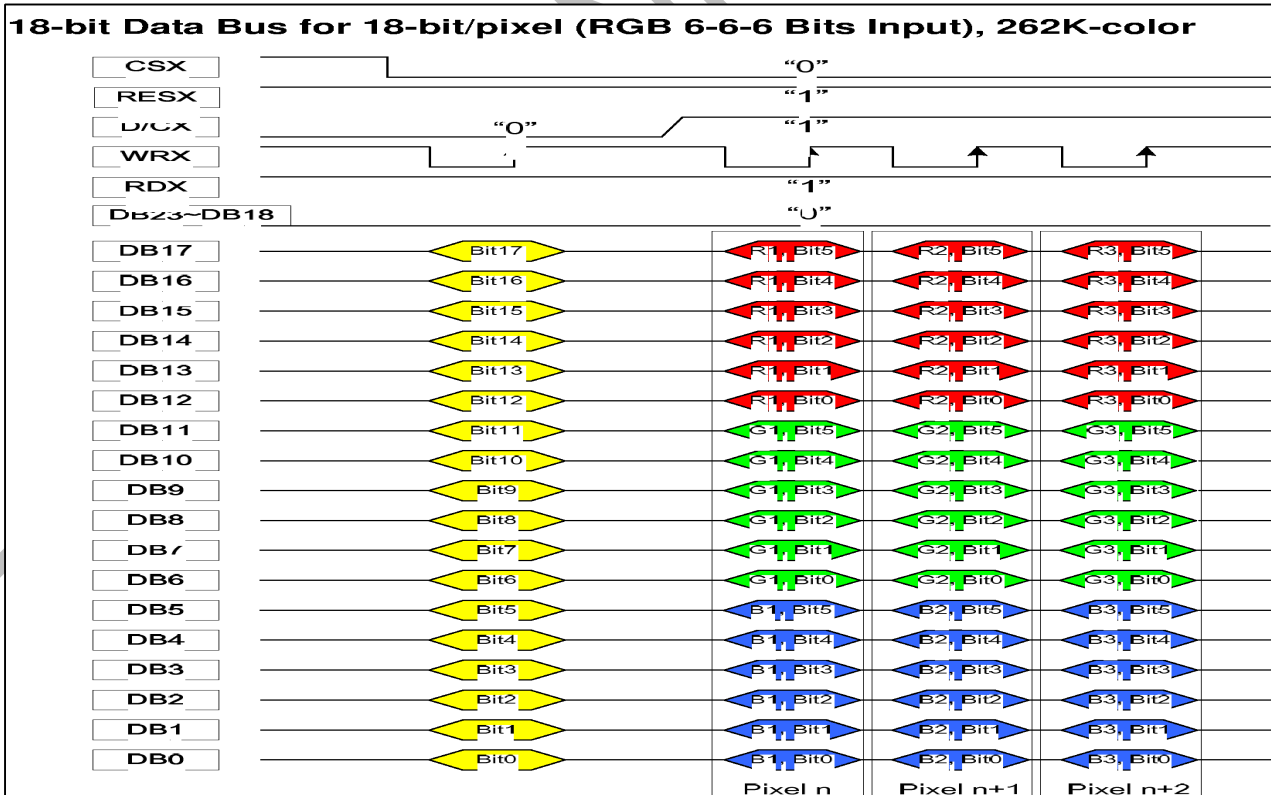

24-bit Data Bus for 24-bit/pixel (RGB 8-8-8 Bits Input), 262K-color

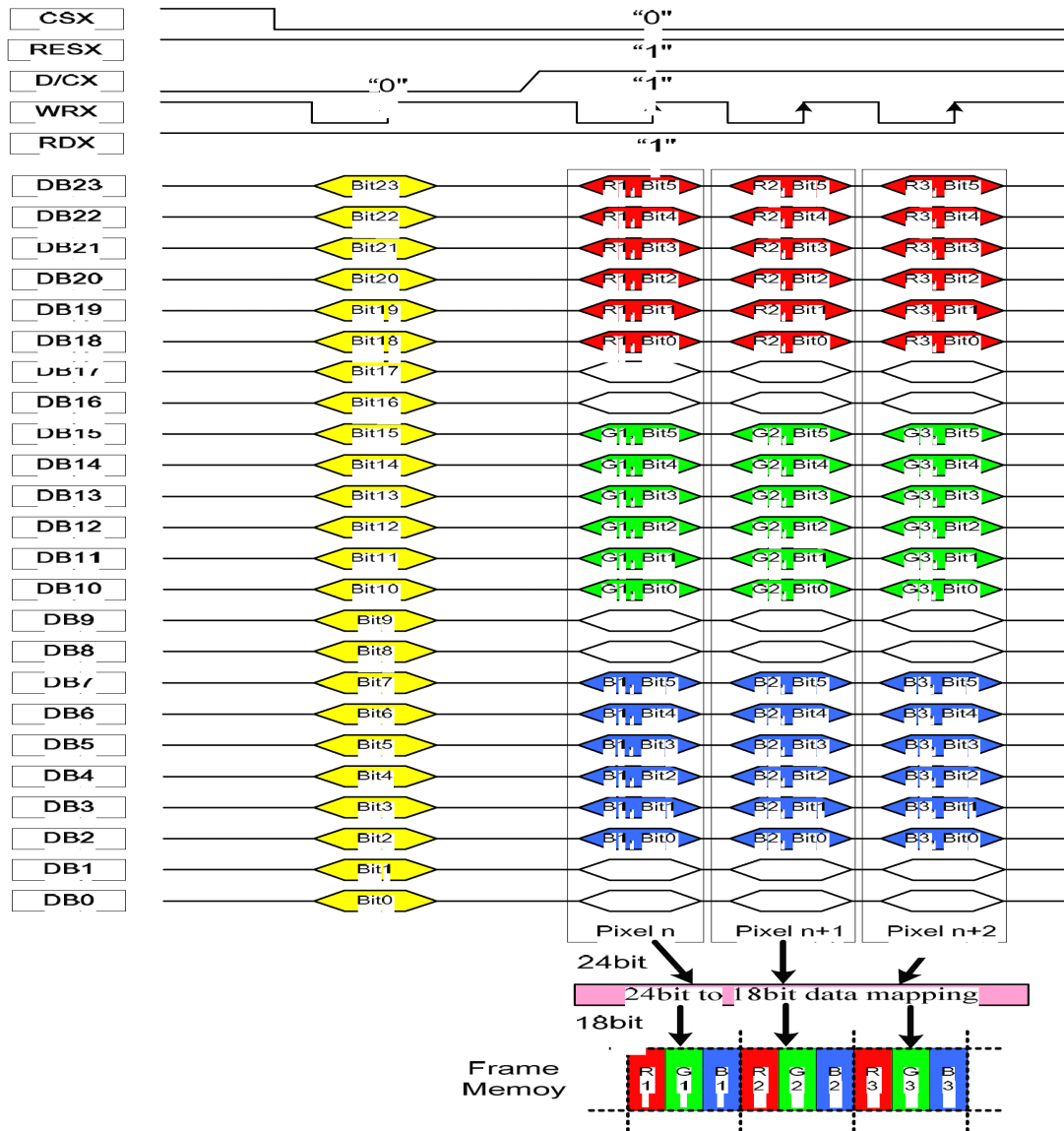

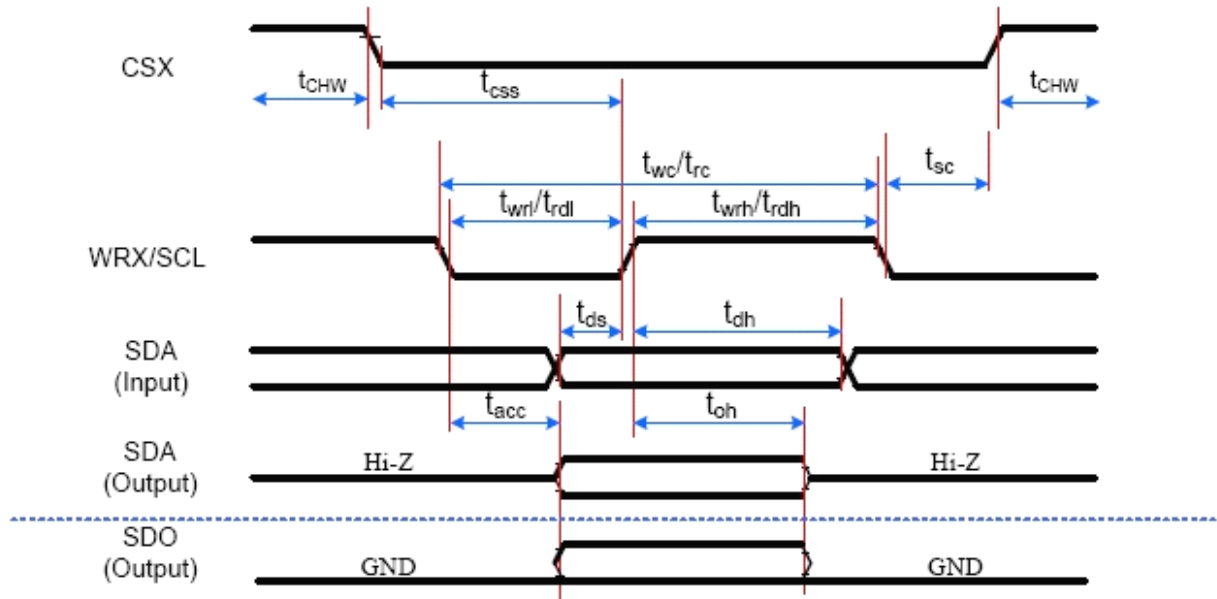
5.2 3-Line SPI Interface Timing Characteristic

Signal	Symbol	Parameter	min	max	Unit	Description
CSX	t_{sc}	SCL-CSX	15	-	ns	
	t_{chw}	CSX H Pulse Width	40	-	ns	
	t_{css}	Chip select time (Write)	60	-	ns	
	t_{csh}	Chip select hold time (Read)	65	-	ns	
SCL	t_{wc}	Serial Clock Cycle (Write)	66	-	ns	
	t_{wrh}	SCL H Pulse Width (Write)	15	-	ns	
	t_{wri}	SCL L Pulse Width (Write)	15	-	ns	
	t_{rc}	Serial Clock Cycle (Read)	150	-	ns	
	t_{rdh}	SCL H Pulse Width (Read)	60	-	ns	
	t_{rdl}	SCL L Pulse Width (Read)	60	-	ns	
SDA (Input)	t_{ds}	Data setup time (Write)	10	-	ns	
	t_{dh}	Data hold time (Write)	10	-	ns	
SDA/SDO (Output)	t_{acc}	Access time (Read)	10	50	ns	For maximum CL=30pF
	t_{oh}	Output disable time (Read)	15	50	ns	For minimum CL=8pF

Note: $T_a = -30$ to 70 °C, $IOVCC = 1.65V$ to $3.3V$, $VCI = 2.5V$ to $3.3V$, $AGND = DGND = 0V$, $T = 10 \pm 0.5ns$

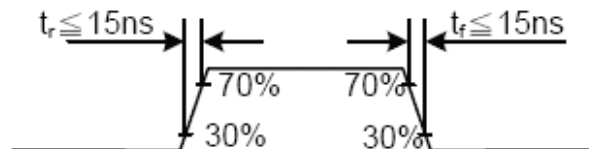

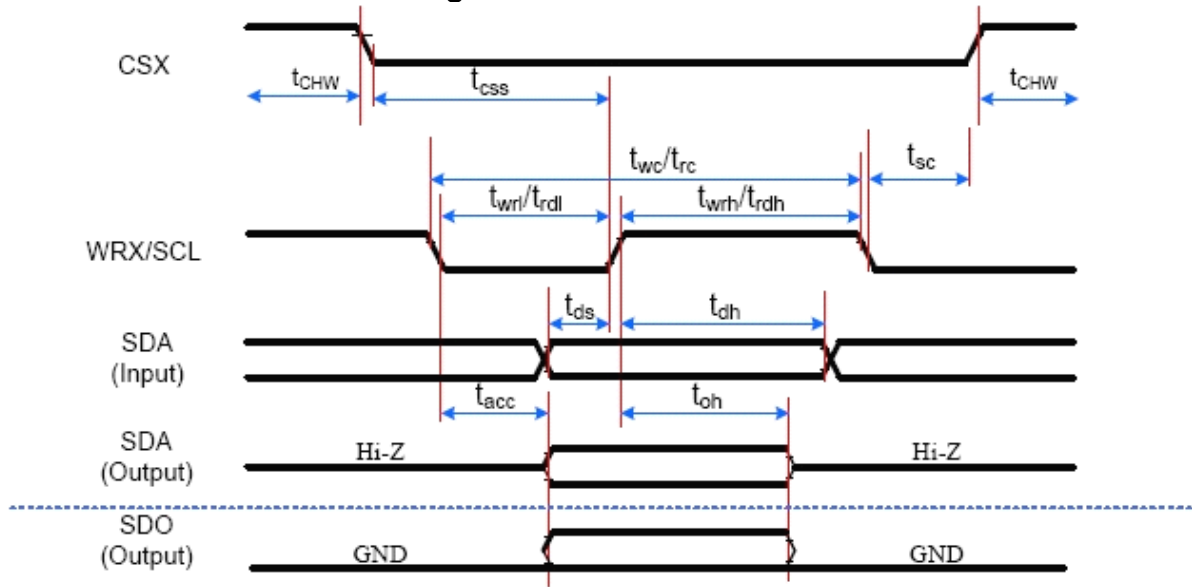
5.3 4-Line SPI Interface Timing Characteristic

Signal	Symbol	Parameter	min	max	Unit	Description
CSX	tsc	SCL-CSX	15	-	ns	
	tchwh	CSX H Pulse Width	40	-	ns	
	tcss	Chip select time (Write)	60	-	ns	
	tcsh	Chip select hold time (Read)	65	-	ns	
SCL	twc	Serial Clock Cycle (Write)	66	-	ns	
	twrh	SCL H Pulse Width (Write)	15	-	ns	
	twrl	SCL L Pulse Width (Write)	15	-	ns	
	trc	Serial Clock Cycle (Read)	150	-	ns	
	trdh	SCL H Pulse Width (Read)	60	-	ns	
	trdl	SCL L Pulse Width (Read)	60	-	ns	
SDA (Input)	tds	Data setup time (Write)	10	-	ns	
	tdh	Data hold time (Write)	10	-	ns	
SDA/SDO (Output)	tacc	Access time (Read)	10	50	ns	For maximum CL=30pF
	toh	Output disable time (Read)	15	50	ns	For minimum CL=8pF

Note: $T_a = -30$ to 70 °C, $I_{OVCC} = 1.65V$ to $3.3V$, $V_{CI} = 2.5V$ to $3.3V$, $AGND = DGND = 0V$, $T = 10 \pm 0.5ns$

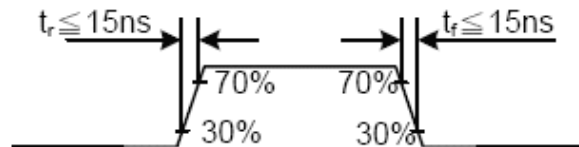

5.4 DPI Interface
5.4.1 DPI Interface Characteristic

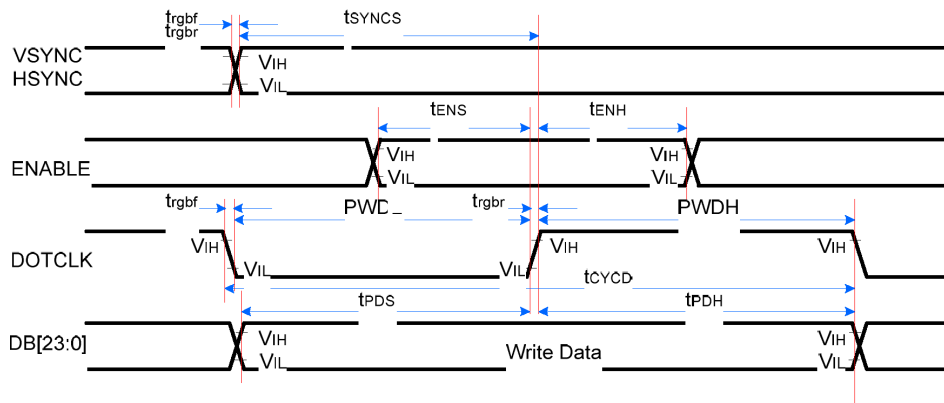

Signal	Symbol	Parameter	min	max	Unit	Description
VSYNC/ HSYNC	t_{SYNCS}	VSYNC/HSYNC setup time	15	-	ns	16-/18-/24-bit bus RGB interface mode
	t_{SYNCH}	VSYNC/HSYNC hold time	15	-	ns	
ENABLE	t_{ENS}	ENABLE setup time	15	-	ns	
	t_{ENH}	ENABLE hold time	15	-	ns	
DB [23:0]	t_{POS}	Data setup time	15	-	ns	
	t_{PDH}	Data hold time	15	-	ns	
DOTCLK	$PWDH$	DOTCLK high-level period	20	-	ns	
	$PWDL$	DOTCLK low-level period	20	-	ns	
	t_{CYCD}	DOTCLK cycle time	50	-	ns	
	t_{rgbr}, t_{rgbl}	DOTCLK,HSYNC,VSYNC rise/fall time	-	15	ns	

Note: $T_a = -30$ to 70 °C, $I_{OVCC} = 1.65V$ to $3.3V$, $V_{CI} = 2.5V$ to $3.3V$, $AGND = DGND = 0V$

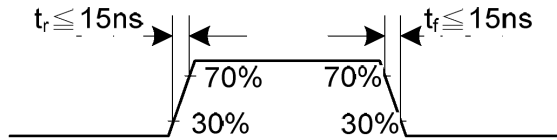

5.4.2 DPI Interface pixel format

24-bit DPI interface connection (DB [23:0] is used): set pixel format DPI [2:0] = 3'h7

DB23	DB22	DB21	DB20	DB19	DB18	DB17	DB16	DB15	DB14	DB13	DB12	DB11	DB10	DB9	DB8	DB7	DB6	DB5	DB4	DB3	DB2	DB1	DB0
R[7]	R[6]	R[5]	R[4]	R[3]	R[2]	R[1]	R[0]	G[7]	G[6]	G[5]	G[4]	G[3]	G[2]	G[1]	G[0]	B[7]	B[6]	B[5]	B[4]	B[3]	B[2]	B[1]	B[0]

18-bit DPI interface connection (DB [17:0] is used): set pixel format DPI [2:0] = 3'h6

DB23	DB22	DB21	DB20	DB19	DB18	DB17	DB16	DB15	DB14	DB13	DB12	DB11	DB10	DB9	DB8	DB7	DB6	DB5	DB4	DB3	DB2	DB1	DB0
						R[5]	R[4]	R[3]	R[2]	R[1]	R[0]	G[5]	G[4]	G[3]	G[2]	G[1]	G[0]	B[5]	B[4]	B[3]	B[2]	B[1]	B[0]

16-bit DPI interface connection (DB [15:0] is used): set pixel format DPI [2:0] = 3'h5

DB23	DB22	DB21	DB20	DB19	DB18	DB17	DB16	DB15	DB14	DB13	DB12	DB11	DB10	DB9	DB8	DB7	DB6	DB5	DB4	DB3	DB2	DB1	DB0
								R[4]	R[3]	R[2]	R[1]	R[0]	G[5]	G[4]	G[3]	G[2]	G[1]	G[0]	B[4]	B[3]	B[2]	B[1]	B[0]

The Pixel clock (DOTCLK) runs all the time without stop. It is used to enter VSYNC, HSYNC, ENABLE and DB [23:0] states when there is a rising edge of the DOTCLK. The DOTCLK cannot be used as the internal clock for other functions of the display module.

Vertical synchronization (VSYNC) is used to indicate when a new frame of the display is received. This is low enable and its state is read to the display module by a rising edge of the DOTCLK signal.

Horizontal synchronization (HSYNC) is used to indicate when a new line of the frame is received. This is low enable and its state is read to the display module by a rising edge of the DOTCLK signal.

Data Enable (ENABLE) is used to indicate when the RGB information that should be transferred in the display is received. This is a high enable, and its state is read to the display module by a rising edge of the DOTCLK signal.

DB [23:0] is used to indicate what is the information of the image that is transferred on the display (when ENABLE = 0 (low) and there is a rising edge of DOTCLK). DB [23:0] can be 0 (low) or 1 (high). These lines are read by a rising edge of the DOTCLK signal. In RGB interface modes, the input display data is written to GRAM first then outputs the corresponding source voltage according to the gray data from GRAM.

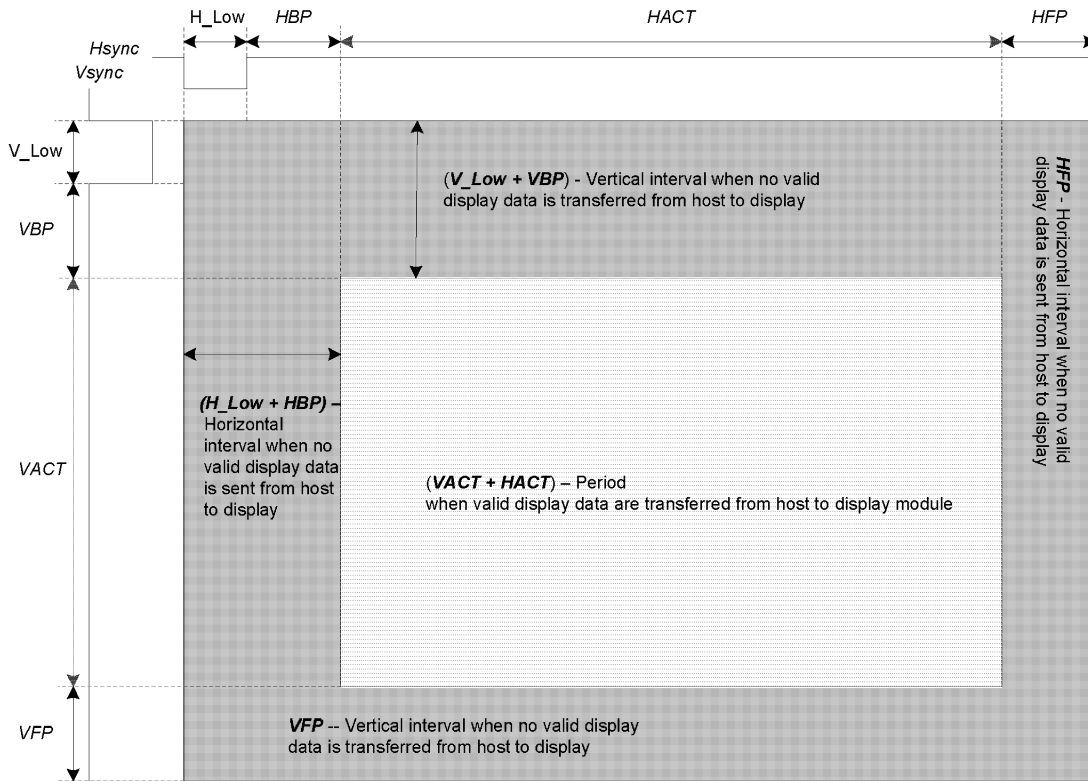

5.4.3 DPI(RGB) Interface timing

Parameters	Symbols	Min.	Typ.	Max.	Units
Horizontal Synchronization	H_Low	3	-	H_Low+HBP <192	DOTCLK
Horizontal Back Porch	HBP	3	-		DOTCLK
Horizontal Front Porch	HFP	3	-	255	DOTCLK
Horizontal Address	HACT	-	320	-	DOTCLK
Horizontal Frequency		-	-	33	KHz
Vertical Synchronization	V_Low	1	-	V_Low+VBP+VFP < 32	Line
Vertical Back Porch	VBP	2	-		Line
Vertical Front Porch	VFP	2	-		Line
Vertical Address	VACT	-	480	-	Line
Vertical Frequency		60	-	70	Hz
DOTCLK cycle		100	-	50	ns
DOTCLK Frequency		10	-	20	MHz

Example : DOTCLK = 20Mhz, TE=70Hz, V_Low+VBP=2, VFP=2, H_Low+HBP=100, HFP=170.

Note: VBP[4:0]/HBP[7:0] (Blanking Porch Control, RB5h) define as follows:

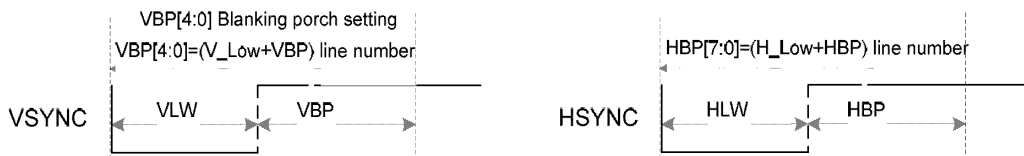

The information contained herein is the exclusive property of TIANMA MICRO-ELECTRONICS Corporation and shall not be distributed, reproduced, or disclosed in whole or in part without prior written permission of TIANMA MICRO-ELECTRONICS Corporation.

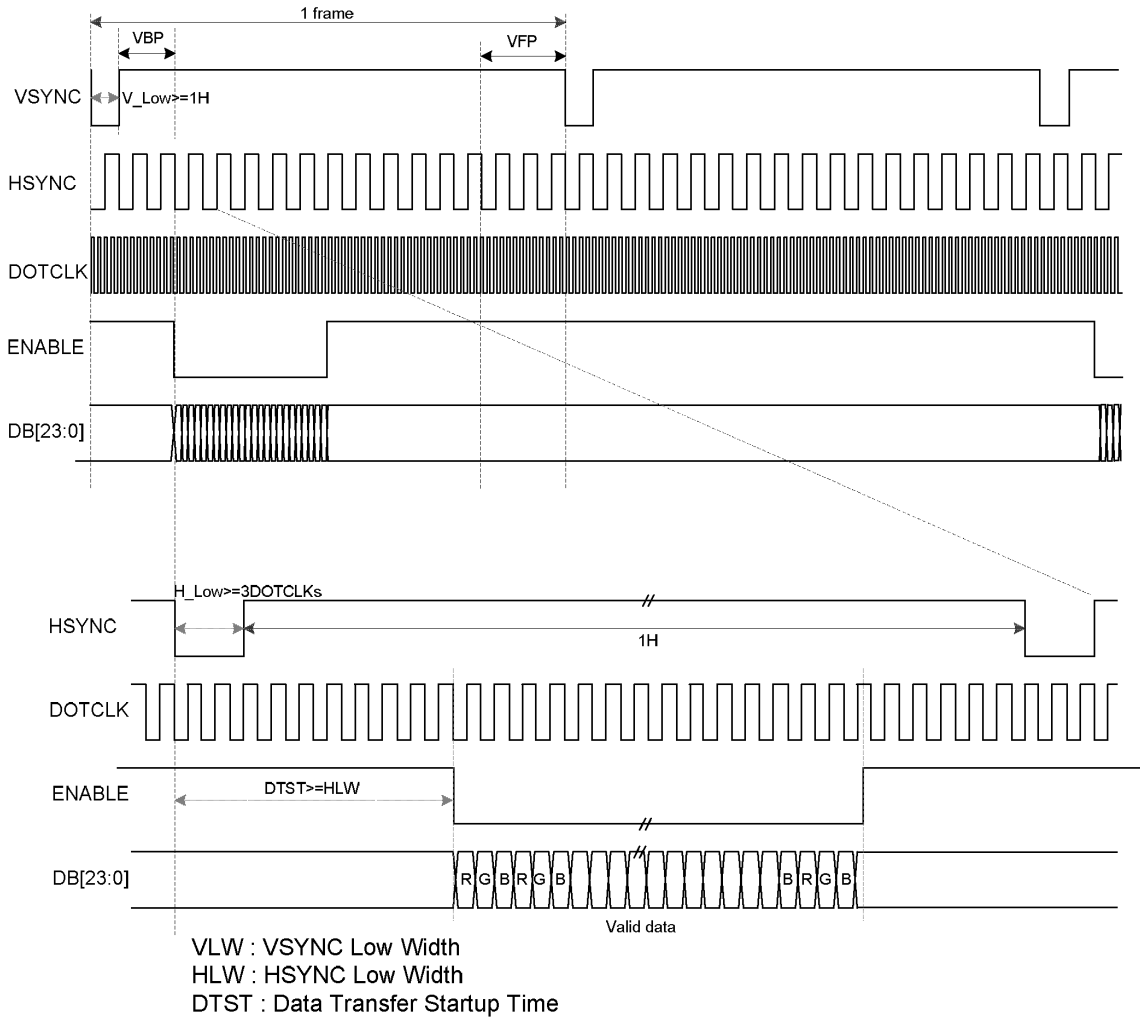

5.5 Power ON/OFF Sequence

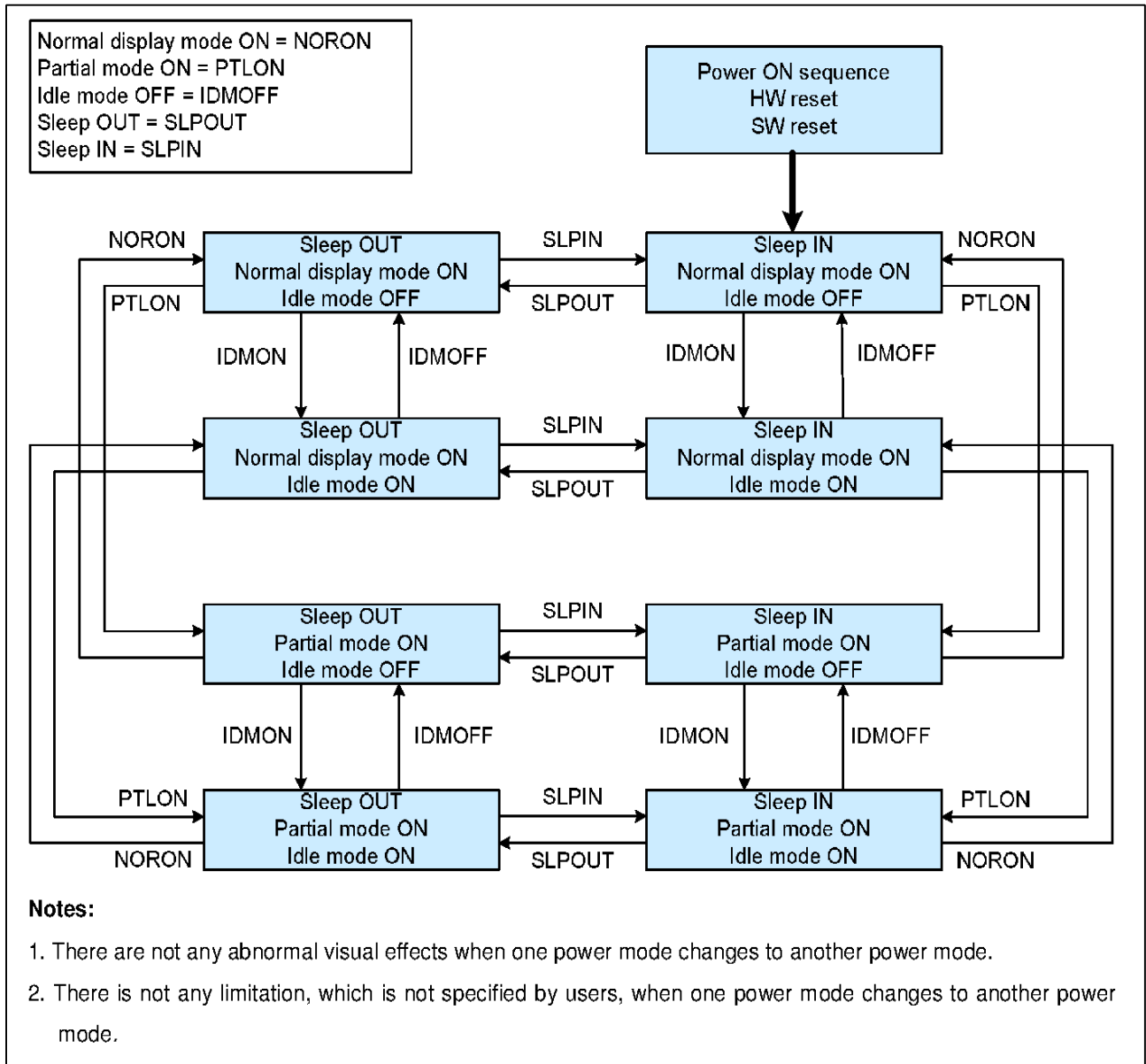

IOVCC and VCI can be applied or powered down in any order. During the Power Off sequence, if the LCD is in the Sleep Out mode, VCI and IOVCC must be powered down with a minimum of 120msec. If the LCD is in the Sleep In mode, VCI and IOVCC can be powered down with a minimum of 0msec after the RESX has been released. CSX can be applied at any time or can be permanently grounded. RESX has high priority over CSX.

Notes:

1. There will be no damage to the ILI9488 if the power sequences are not met.
2. There will be no abnormal visible effects on the display panel during the Power On/Off Sequence.
3. There will be no abnormal visible effects on the display between the end of the Power On Sequence and before receiving the Sleep Out command, and also between receiving the Sleep In command and the Power Off Sequence.
4. If the RESX line is not steadily held by the host during the Power On Sequence as defined in Sections 11.1 and 11.2, then it will be necessary to apply the Hardware Reset (RESX) after the completion of the Host Power On Sequence to ensure correct operations. Otherwise, all the functions are not guaranteed.
5. When the power is turned on, the climb period timing(T_{rise}) must be greater than 10 μ s.
6. Keep data pins DB[23:0] at low level, when VCI or IOVCC comes later

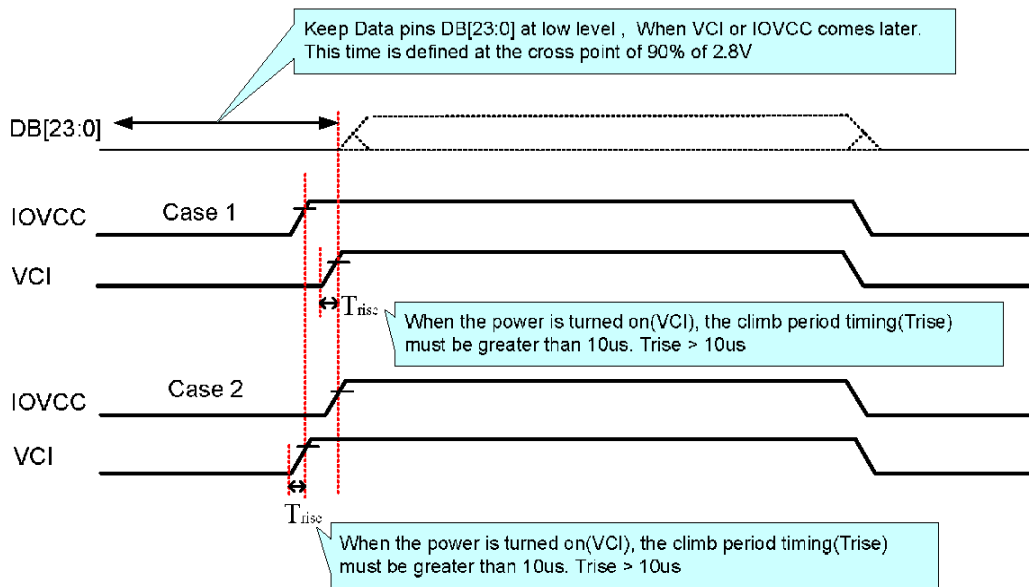

5.6 Reset timing

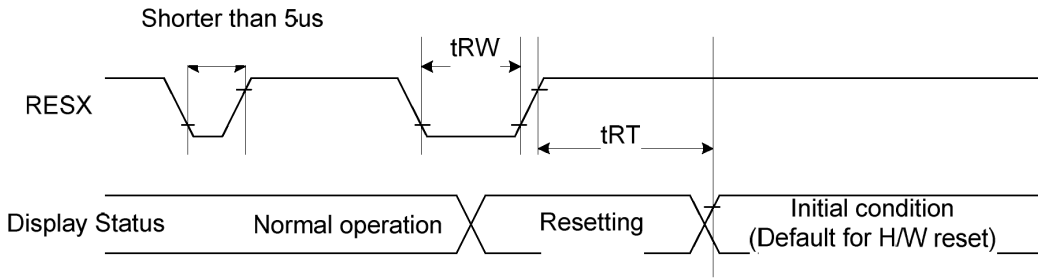

Table 39: Reset Timing

Signal	Symbol	Parameter	Min	Max	Unit
RESX	tRW	Reset pulse duration	10		uS
	tRT	Reset cancel		5 (note 1,5) 120 (note 1,6,7)	mS

Notes:

1. The reset cancel also includes the required time for loading ID bytes, VCOM setting and other settings from the EEPROM to registers. After a rising edge of RESX, this loading is done within 5 ms after the H/W reset cancel (tRT).
2. According to the Table 40, a spike due to an electrostatic discharge on the RESX line does not cause irregular system reset.

Table 40: Reset Description

RESX Pulse	Action
Shorter than 5us	Reset Rejected
Longer than 9us	Reset
Between 5us and 9us	Reset starts

3. During the Reset period, the display will be blanked (When Reset starts in the Sleep Out mode, the display will enter the blanking sequence in at least 120 ms. The display remains the blank state in the Sleep In mode.) and then return to the default condition for the Hardware Reset.
4. Spike Rejection can also be applied during a valid reset pulse, as shown below:

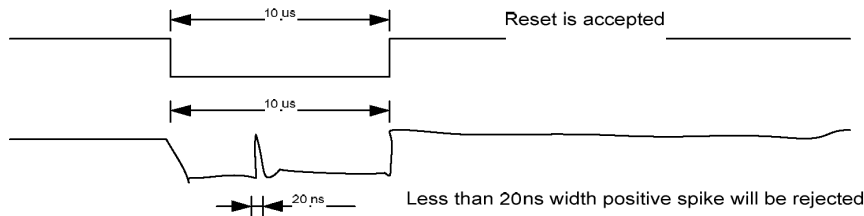

Figure 137: Positive Noise Pulse during Reset Low

6 Optical Characteristics

Item	Symbol	Condition	Min	Typ	Max	Unit	Remark	
View Angles	θT	$CR \geq 10$	60	70		Degree	Note2,3	
	θB		50	60				
	θL		60	70				
	θR		60	70				
Contrast Ratio	CR	$\theta=0^\circ$	400	500			Note 3	
Response Time	T_{ON}	25°C		25	35	ms	Note 4	
	T_{OFF}							
Chromaticity	White	x		0.286			Note 1,5	
		y		0.304				
	Red	x	Backlight is on		0.608			Note 1,5
		y			0.336			
	Green	x			0.341			Note 1,5
		y			0.604			
	Blue	x			0.146			Note 1,5
		y			0.073			
Uniformity	U				80		%	Note 6
NTSC					60		%	Note 5
Luminance	L		250	300		cd/m ²	Note 7	

Test Conditions:

1. $I_F = 20$ mA, and the ambient temperature is 25°C.
2. The test systems refer to Note 1 and Note 2.

Note 1: Definition of optical measurement system.

The optical characteristics should be measured in dark room. After 5 Minutes operation, the optical properties are measured at the center point of the LCD screen. All input terminals LCD panel must be ground when measuring the center area of the panel.

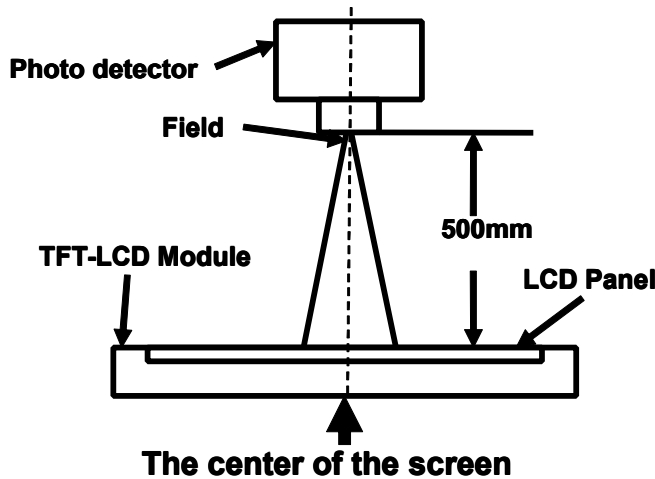

Note 2: Definition of viewing angle range and measurement system.

viewing angle is measured at the center point of the LCD.

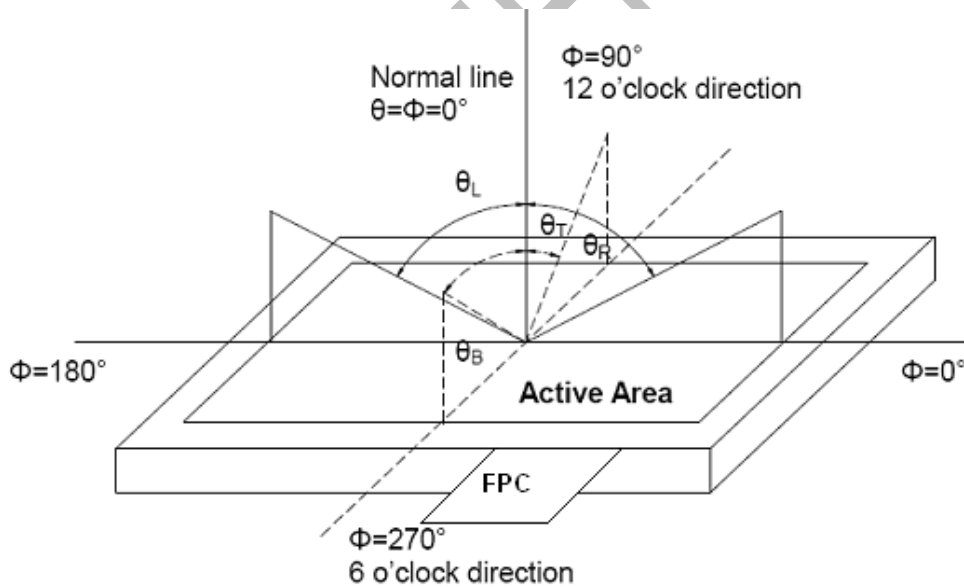

Note 3: Definition of contrast ratio

$$\text{Contrast ratio (CR)} = \frac{\text{Luminance measured when LCD is on the "White" state}}{\text{Luminance measured when LCD is on the "Black" state}}$$

“White state “: The state is that the LCD should drive by V_{white} .

“Black state”: The state is that the LCD should drive by V_{black} .

V_{white} : To be determined V_{black} : To be determined.

Note 4: Definition of Response time

The response time is defined as the LCD optical switching time interval between “White” state and “Black” state. Rise time (T_{ON}) is the time between photo detector output intensity changed from 90% to 10%. And fall time (T_{OFF}) is the time between photo detector output intensity changed from 10% to 90%.

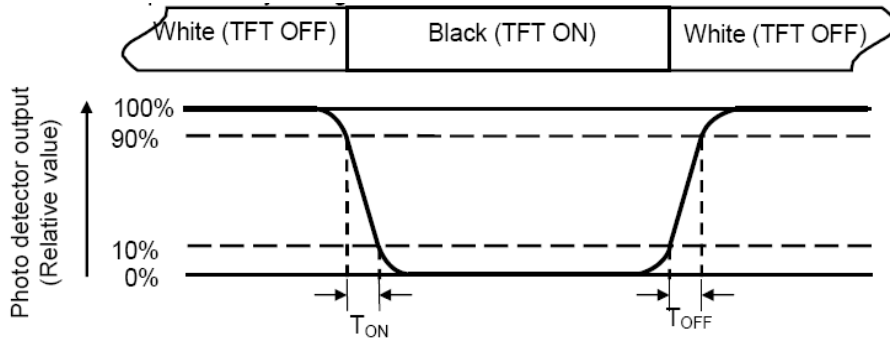

Note 5: Definition of color chromaticity (CIE1931)

Color coordinates measured at center point of LCD.

Note 6: Definition of Luminance Uniformity

Active area is divided into 9 measuring areas (Refer Fig. 2). Every measuring point is placed at the center of each measuring area.

$$\text{Luminance Uniformity (U)} = L_{\min} / L_{\max}$$

L-----Active area length W----- Active area width

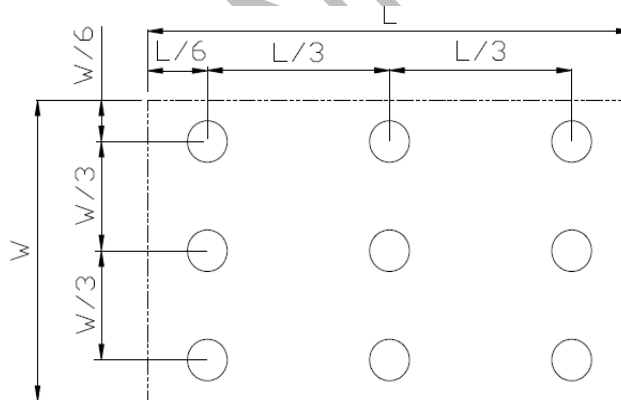

L_{\max} : The measured Maximum luminance of all measurement position.

L_{\min} : The measured Minimum luminance of all measurement position.

Note 7: Definition of Luminance:

Measure the luminance of white state at center point.

7 Environmental / Reliability Test

No	Test Item	Condition	Remarks
1	High Temperature Operation	Ts=+70℃, 240hrs	Note1 IEC60068-2-1,GB2423.2
2	Low Temperature Operation	Ta=-20℃, 240hrs	IEC60068-2-1 GB2423.1
3	High Temperature Storage	Ta=+80℃, 240hrs	IEC60068-2-1 GB2423.1
4	Low Temperature Storage	Ta=-30℃, 240hrs	IEC60068-2-1 GB2423.1
5	High Temperature and Humidity Operation	Ta=+60℃, 90% RH 240 hours	Note2 IEC60068-2-78 GB/T2423.3
6	Thermal Shock (non-operation)	-30℃ 30 min~+70℃ 30 min, Change time:5min, 20 Cycles	Start with cold temperature, End with high temperature, IEC60068-2-14,GB2423.22
7	Electro Static Discharge (Operation)	C=150pF, R=330 , 5points/panel Air:±6KV, 5times; Contact:±4KV, 5 times; (Environment: 15℃~35℃, 30%~60%, 86Kpa~106Kpa)	IEC61000-4-2 GB/T17626.2
8	Vibration (Non-operation)	Frequency range:10~55Hz, Stroke:1.5mm Sweep:10Hz~55Hz~10Hz 2 hours for each direction of X.Y.Z. (6 hours for total) (Package condition)	IEC60068-2-6 GB/T2423.10
9	Shock (Non-operation)	60G 6ms, ±X,±Y,±Z 3times, for each direction	IEC60068-2-27 GB/T2423.5
10	Package Drop Test	Height:80 cm, 1 corner, 3 edges, 6 surfaces	IEC60068-2-32 GB/T2423.8

Note1: Ts is the temperature of panel's surface.

Note2: Ta is the ambient temperature of sample.

Note3: Before cosmetic and function test, the product must have enough recovery time, at least 2 hours at room temperature.

Note 4: In the standard condition, there shall be no practical problem that may affect the display function. After the reliability test, the product only guarantees operation, but don't guarantee all of the cosmetic specification.

8 Mechanical Drawing

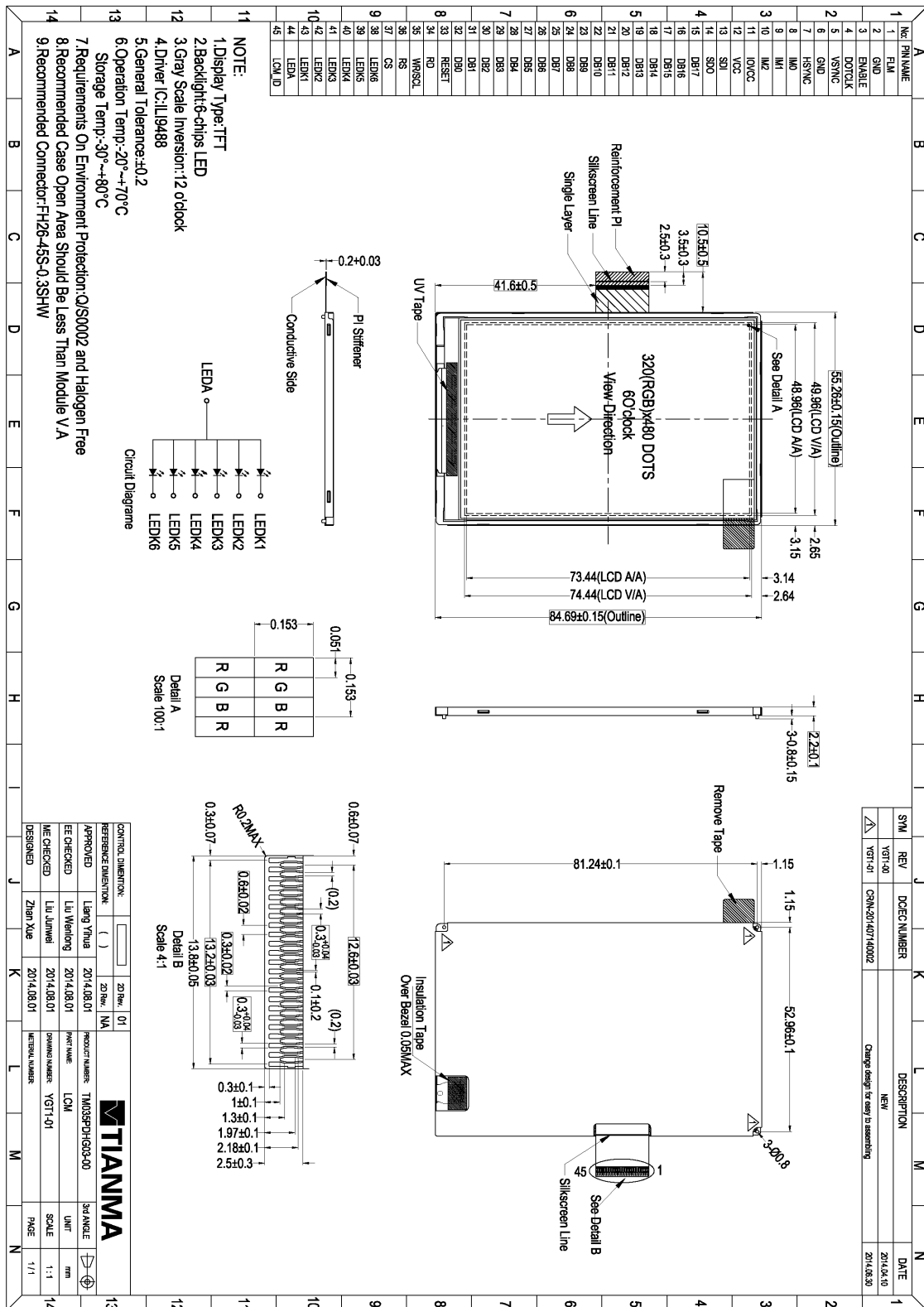

The information contained herein is the exclusive property of TIANMA MICRO-ELECTRONICS Corporation and shall not be distributed, reproduced, or disclosed in whole or in part without prior written permission of TIANMA MICRO-ELECTRONICS Corporation.

9 Packing Drawing

Per Carton

No	Item	Model (Material)	Dimensions(mm)	Unit Weight(Kg)	Quantity	Remark	
1	LCM module	TM035PDHG03-00	55.26*84.69*2.2	0.021	324		
2	Tray	PET(Transmit)	485x330x13	0.117	21	Anti-static	
3	EPE	EPE	485*330*5	0.083	9		
4	Desiccant	Desiccant	45X35	0.002	6		
5	Dust-Proof Bag	PE	700*545	0.046	3		
6	Box	Corrugated Paper	520*345*74	0.3879	3		
7	Carton	Corrugated Paper	544*365*250	1.01	1		
8	Total weight	$12.45 \pm 5\%$ Kg					

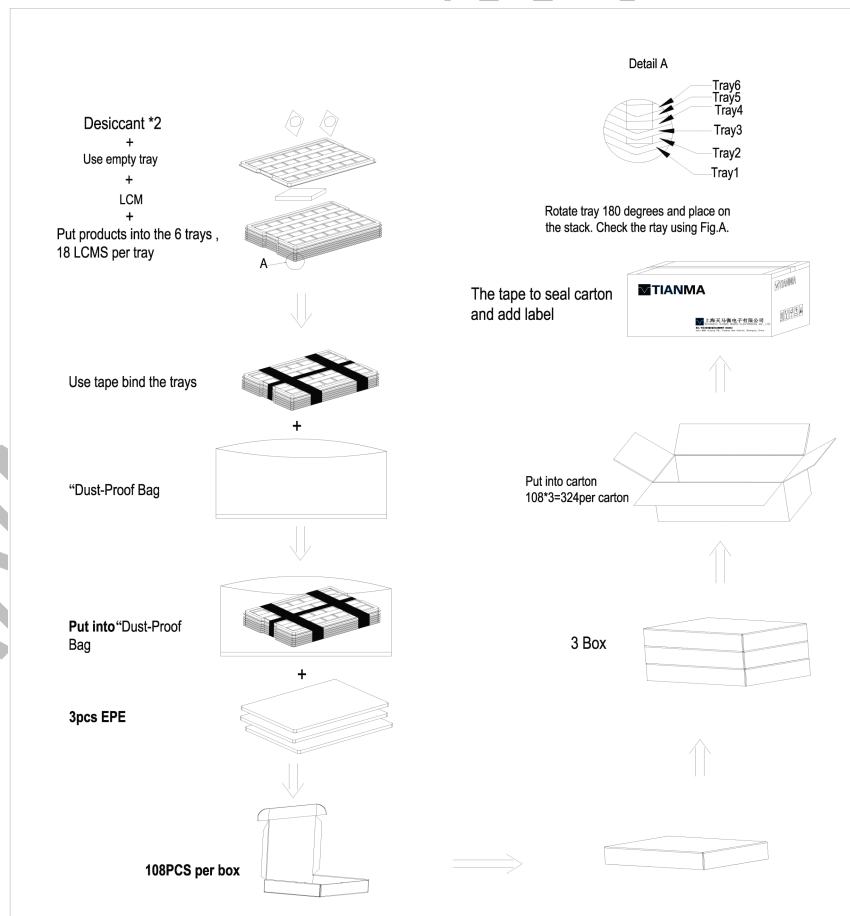

The information contained herein is the exclusive property of TIANMA MICRO-ELECTRONICS Corporation and shall not be distributed, reproduced, or disclosed in whole or in part without prior written permission of TIANMA MICRO-ELECTRONICS Corporation.

10 Precautions for Use of LCD Modules

10.6 Handling Precautions

10.6.1 The display panel is made of glass. Do not subject it to a mechanical shock by dropping it from a high place, etc.

10.6.2 If the display panel is damaged and the liquid crystal substance inside it leaks out, be sure not to get any in your mouth, if the substance comes into contact with your skin or clothes, promptly wash it off using soap and water.

10.6.3 Do not apply excessive force to the display surface or the adjoining areas since this may cause the color tone to vary.

10.6.4 The polarizer covering the display surface of the LCD module is soft and easily scratched. Handle this polarizer carefully.

10.6.5 If the display surface is contaminated, breathe on the surface and gently wipe it with a soft dry cloth. If still not completely clear, moisten cloth with one of the following solvents:

- Isopropyl alcohol
- Ethyl alcohol

Solvents other than those mentioned above may damage the polarizer. Especially, do not use the following:

- Water
- Ketone
- Aromatic solvents

10.6.6 Do not attempt to disassemble the LCD Module.

10.6.7 If the logic circuit power is off, do not apply the input signals.

10.6.8 To prevent destruction of the elements by static electricity, be careful to maintain an optimum work environment.

10.1.8.1 Be sure to ground the body when handling the LCD Modules.

10.1.8.2 Tools required for assembly, such as soldering irons, must be properly ground.

10.1.8.3 To reduce the amount of static electricity generated, do not conduct assembly and other work under dry conditions.

10.1.8.4 The LCD Module is coated with a film to protect the display surface. Be care when peeling off this protective film since static electricity may be generated.

10.7 Storage precautions

10.7.1 When storing the LCD modules, avoid exposure to direct sunlight or to the light of fluorescent lamps.

10.7.2 The LCD modules should be stored under the storage temperature range. If the LCD modules will be stored for a long time, the recommend condition is:

Temperature : 0°C ~ 40°C Relatively humidity: ≤80%

10.7.3 The LCD modules should be stored in the room without acid, alkali and harmful gas.

10.8 Transportation Precautions

10.8.1 The LCD modules should be no falling and violent shocking during transportation, and also should avoid excessive press, water, damp and sunshine.